

XRAY T2

1/10 LUXURY TOURING CAR

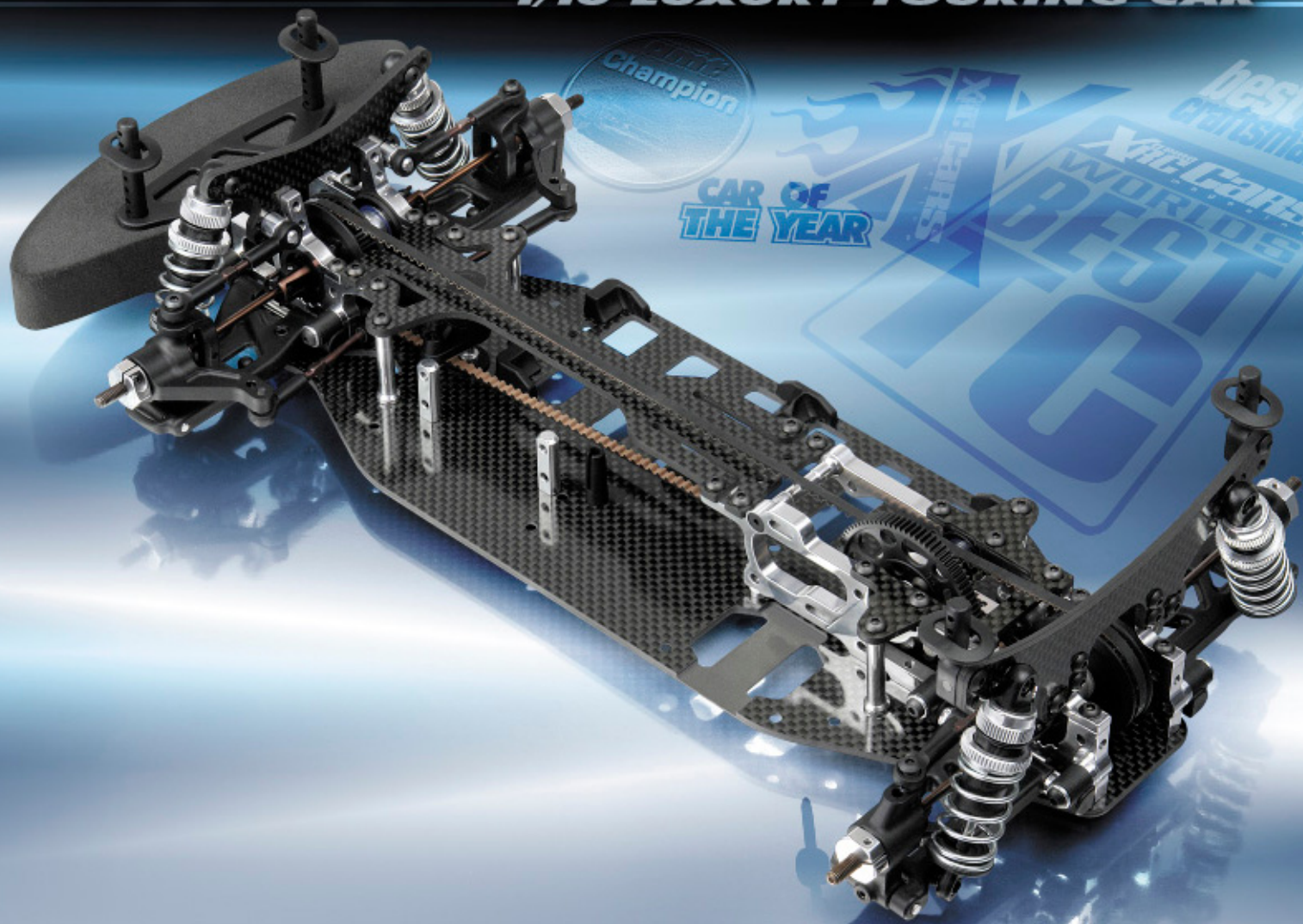

INSTRUCTION MANUAL

XRAY

BEFORE YOU START

The T2 is a high-competition, high-quality, 1/10-scale touring car intended for persons aged 16 years and older with previous experience building and operating RC model racing cars. This is not a toy; it is a precision racing model. This model racing car is not intended for use by beginners, inexperienced customers, or by children without direct supervision of a responsible, knowledgeable adult. If you do not fulfill these requirements, please return the kit in unused and unassembled form back to the shop where you have purchased it.

Before building and operating your T2, **YOU MUST** read through all of the operating instructions and instruction manual and fully understand them to get

CUSTOMER SUPPORT

We have made every effort to make these instructions as easy to understand as possible. However, if you have any difficulties, problems, or questions, please do not hesitate to contact the XRAY support team at info@teamxray.com. Also, please visit our Web site at www.teamxray.com to find the latest updates, set-up information, option parts, and many other goodies. We pride ourselves on taking excellent care of our customers.

You can join thousands of XRAY fans and enthusiasts in our online community at:

www.teamxray.com

Failure to follow these instructions will be considered as abuse and/or neglect.

SAFETY PRECAUTIONS

Contains:

LEAD (CAS 7439-92-1) ANTIMONY (CAS 7440-36-0)

WARNING: This product contains a chemical known to the state of California to cause cancer and birth defects or other reproductive harm.

CAUTION: CANCER HAZARD

Contains lead, a listed carcinogen. Lead is harmful if ingested. Wash thoroughly after using. DO NOT use product while eating, drinking or using tobacco products. May cause chronic effects to gastrointestinal tract, CNS, kidneys, and blood. MAY CAUSE BIRTH DEFECTS.

When building, using and/or operating this model always wear protective glasses and gloves.

Take appropriate safety precautions prior to operating this model. You are responsible for this model's assembly and safe operation! Please read the instruction manual before building and operating this model and follow all safety precautions. Always keep the instruction manual at hand for quick reference, even after completing the assembly. Use only genuine and original authentic XRAY parts for maximum performance. Using any third party parts on this model will void guaranty immediately.

IMPORTANT NOTES - GENERAL

- This product is not suitable for children under 16 years of age without the direct supervision of a responsible and knowledgeable adult.
- Carefully read all manufacturers warnings and cautions for any parts used in the construction and use of your model.
- Assemble this kit only in places away from the reach of very small children.
- First-time builders and users should seek advice from people who have building experience in order to assemble the model correctly and to allow the model to reach its performance potential.
- Exercise care when using tools and sharp instruments.
- Take care when building, as some parts may have sharp edges.
- Keep small parts out of reach of small children. Children must not be allowed to put any parts in their mouth, or pull vinyl bag over their head.
- Read and follow instructions supplied with paints and/or cement, if used (not included in kit).
- Immediately after using your model, do NOT touch equipment on the model such as the motor and speed controller, because they generate high temperatures. You may seriously burn yourself seriously touching them.
- Follow the operating instructions for the radio equipment at all times.
- Do not put fingers or any objects inside rotating and moving parts, as this may cause damage or serious injury as your finger, hair, clothes, etc. may get caught.
- Be sure that your operating frequency is clear before turning on or running your model, and never share the same frequency with somebody else at the same time. Ensure that others are aware of the operating frequency you are using and when you are using it.
- Use a transmitter designed for ground use with RC cars. Make sure that no one else is using the same frequency as yours in your operating area. Using the same frequency at the same time, whether it is driving, flying or sailing, can cause loss of control of the RC model, resulting in a serious accident.
- Always turn on your transmitter before you turn on the receiver in the car. Always turn off the receiver before turning your transmitter off.
- Keep the wheels of the model off the ground when checking the operation of the radio equipment.
- Disconnect the battery pack before storing your model.
- When learning to operate your model, go to an area that has no obstacles that can damage your model if your model suffers a collision.
- Remove any sand, mud, dirt, grass or water before putting your model away.
- If the model behaves strangely, immediately stop the model, check and clear the problem.
- To prevent any serious personal injury and/or damage to property, be responsible when operating all remote controlled models.
- The model car is not intended for use on public places and roads or areas where its operation can conflict with or disrupt pedestrian or vehicular traffic.
- Because the model car is controlled by radio, it is subject to radio interference from many sources that are beyond your control. Since radio interference can cause momentary loss of control, always allow a safety margin in all directions around the model in order to prevent collisions.
- Do not use your model:
 - Near real cars, animals, or people that are unaware that an RC car is being driven.
 - In places where children and people gather
 - In residential districts and parks
 - In limited indoor spaces
 - In wet conditions
 - In the street
 - In areas where loud noises can disturb others, such as hospitals and residential areas.
 - At night or anytime your line of sight to the model may be obstructed or impaired in any way.

the maximum enjoyment and prevent unnecessary damage. Read carefully and fully understand the instructions before beginning assembly.

Make sure you review this entire manual, the included set-up book, and examine all details carefully. If for some reason you decide the T2 is not what you wanted or expected, **do not continue any further**. Your hobby dealer cannot accept your T2 kit for return or exchange after it has been partially or fully assembled.

Contents of the box may differ from pictures. In line with our policy of continuous product development, the exact specifications of the kit may vary without prior notice.

XRAY Europe

Pred Polom 762
91101 Trenčín
Slovakia, EUROPE
Phone: 421-32-7440180
Fax: 421-32-7440179
Email: info@teamxray.com

XRAY USA

RCAmerica, 167 Turtle Creek Boulevard Suite C
Dallas, Texas 75207
USA
Phone: (800) 519-7221 * (214) 744-2400
Fax: (214) 744-2401
Email: xray@rcamerica.com

Improper operation may cause personal and/or property damage. XRAY and its distributors have no control over damage resulting from shipping, improper construction, or improper usage. XRAY assumes and accepts no responsibility for personal and/or property damages resulting from the use of improper building materials, equipment and operations. By purchasing any item produced by XRAY, the buyer expressly warrants that he/she is in compliance with all applicable federal, state and local laws and regulation regarding the purchase, ownership and use of the item. The buyer expressly agrees to indemnify and hold harmless XRAY for all claims resulting directly or indirectly from the purchase, ownership or use of the product. By the act of assembling or operating this product, the user accepts all resulting liability. If the buyer is not prepared to accept this liability, then he/she should return this kit in new, unassembled, and unused condition to the place of purchase.

To prevent any serious personal injury and/or damage to property, please be responsible when operating all remote controlled models.

IMPORTANT NOTES – ELECTRICAL

- Insulate any exposed electrical wiring (using heat shrink tubing or electrical tape) to prevent dangerous short circuits. Take maximum care in wiring, connecting and insulating cables. Make sure cables are always connected securely. Check connectors for if they become loose. And if so, reconnect them securely. Never use R/C models with damaged wires. A damaged wire is extremely dangerous, and can cause short-circuits resulting in fire. Please have wires repaired at your local hobby shop.
- Low battery power will result in loss of control. Loss of control can occur due to a weak battery in either the transmitter or the receiver. Weak running battery may also result in an out of control car if your car's receiver power is supplied by the running battery. Stop operation immediately if the car starts to slow down.
- When not using RC model, always disconnect and remove battery.
- Do not disassemble battery or cut battery cables. If the running battery short-circuits, approximately 300W of electricity can be discharged, leading to fire or burns. Never disassemble battery or cut battery cables.
- Use a recommended charger for the receiver and transmitter batteries and follow the instructions correctly. Over-charging, incorrect charging, or using inferior chargers can cause the batteries to become dangerously hot.

Recharge battery when necessary. Continual recharging may damage battery and, in the worst case, could build up heat leading to fire. If battery becomes extremely hot during recharging, please ask your local hobby shop for check and/or repair and/or replacement.

- Regularly check the charger for potential hazards such as damage to the cable, plug, casing or other defects. Ensure that any damage is rectified before using the charger again. Modifying the charger may cause short-circuit or overcharging leading to a serious accident. Therefore do not modify the charger.
- Always unplug charger when recharging is finished.
- Do not recharge battery while battery is still warm. After use, battery retains heat. Wait until it cools down before charging.
- Do not allow any metal part to short circuit the receiver batteries or other electrical/electronic device on the model.
- Immediately stop running if your RC model gets wet as may cause short circuit.
- Please dispose of batteries responsibly. Never put batteries into fire.

R/C & BUILDING TIPS

- Make sure all fasteners are properly tightened. Check them periodically.
- Make sure that chassis screws do not protrude from the chassis.
- For the best performance, it is very important that great care is taken to ensure the free movement of all parts.
- Clean all ball-bearings so they move very easily and freely.
- Tap or pre-thread the plastic parts when threading screws.
- Self-tapping screws cut threads into the parts when being tightened. Do not use excessive force when tightening the self-tapping screws because you may strip out the thread in the plastic. We recommended you stop tightening a screw when you feel some resistance.
- Ask your local hobby shop for any advice.

Please support your local hobby shop. We at XRAY Model Racing Cars support all local hobby dealers. Therefore we ask you, if at all possible, to purchase XRAY products at your hobby dealer and give them your support like we do. If you have difficulty finding XRAY products, please check out www.teamxray.com to get advice, or contact us via email at info@teamxray.com, or contact the XRAY distributor in your country.

WARRANTY

XRAY guarantees this model kit to be free from defects in both material and workmanship within 30 days of purchase. The total monetary value under warranty will in no case exceed the cost of the original kit purchased. This warranty does not cover any components damaged by use or modification or as a result of wear. Part or parts missing from this kit must be reported within 30 days of purchase. No part or parts will be sent under warranty without proof of purchase. Should you find a defective or missing part, contact the local distributor. Service and customer support will be provided through local hobby store where you have purchased the kit, therefore make sure to purchase any XRAY products at your local hobby store. This model racing car is considered to be a high-performance racing vehicle. As such this vehicle will be used in an extreme range of conditions and situations, all which may cause premature wear or failure of any component. XRAY has no control over usage of vehicles once they leave the dealer, therefore XRAY can only offer warranty against all manufacturer's defects in materials, workmanship, and assembly at point of sale and before use. No warranties are expressed or implied that cover damage caused by what is considered normal use, or cover or imply how long any model cars' components or electronic components will last before requiring replacement.

Due to the high performance level of this model car you will need to periodically maintain and replace consumable components. Any and all warranty coverage will not cover replacement of any part or component damaged by neglect, abuse, or improper or unreasonable use. This includes but is not limited to

damage from crashing, chemical and/or water damage, excessive moisture, improper or no maintenance, or user modifications which compromise the integrity of components. Warranty will not cover components that are considered consumable on RC vehicles. XRAY does not pay nor refund shipping on any component sent to XRAY or its distributors for warranty. XRAY reserves the right to make the final determination of the warranty status of any component or part.

Limitations of Liability

XRAY makes no other warranties expressed or implied. XRAY shall not be liable for any loss, injury or damages, whether direct, indirect, special, incidental, or consequential, arising from the use, misuse, or abuse of this product and/or any product or accessory required to operate this product. In no case shall XRAY's liability exceed the monetary value of this product.

Take adequate safety precautions prior to operating this model. You are responsible for this model's assembly and safe operation.

Disregard of the any of the above cautions may lead to accidents, personal injury, or property damage. XRAY MODEL RACING CARS assumes no responsibility for any injury, damage, or misuse of this product during assembly or operation, nor any addictions that may arise from the use of this product.

All rights reserved.

QUALITY CERTIFICATE

XRAY MODEL RACING CARS uses only the highest quality materials, the best compounds for molded parts and the most sophisticated manufacturing processes of TQM (Total Quality Management). We guarantee that all parts of a newly-purchased kit are manufactured with the highest regard to quality. However, due to the many factors inherent in model racecar competition, we cannot guarantee

any parts once you start racing the car. Products which have been worn out, abused, neglected or improperly operated will not be covered under warranty. We wish you enjoyment of this high-quality and high-performance RC car and wish you best success on the track!













In line with our policy of continuous product development, the exact specifications of the kit may vary. In the unlikely event of any problems with your new kit, you should contact the model shop where you purchased it, quoting the part number.

We do reserve all rights to change any specification without prior notice. All rights reserved.





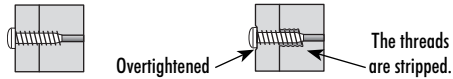

CONTENTS

| | | | |
|--|-------|---|-------|
| WARNINGS | 2-3 | 4. FRONT & REAR TRANSMISSION | 14-17 |
| TOOLS AND ACCESSORIES | 4 | 5. STEERING | 18-19 |
| 0. KIT | 5 | 6. SHOCK ABSORBERS | 20-21 |
| 1. BALL DIFFERENTIAL & FRONT MULTI-DIFF | 6-7 | 7. FRONT & REAR ASSEMBLY | 22-24 |
| 2. FRONT & REAR SUSPENSION | 8-10 | 8. FINAL ASSEMBLY | 25-27 |
| 3. CENTRAL TRANSMISSION | 11-13 | | |

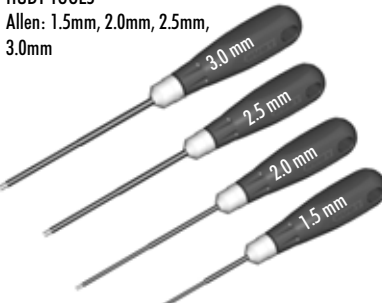

SYMBOLS USED

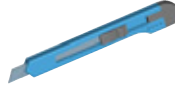
| | | | | | | |
|---|--|---|---|--|---|--|
| Part bags used  | Assemble in the specified order  | Assemble left and right sides the same way  | Pay attention here  | Assemble as many times as specified (here twice)  | Apply thread lock  | Apply CA glue  |
| Apply oil  | Apply grease  | Use pliers  | Ensure smooth non-binding movement  | Tighten screw gently  | <p>CORRECT ✓ WRONG ✗</p>  <p>Overtightened → The threads are stripped.</p> | |







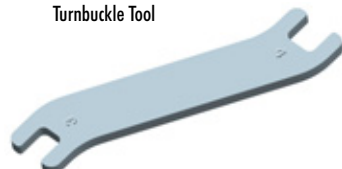

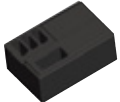

TOOLS REQUIRED

| | | | | | |
|---|---|---|--|--|---|
| HUDY TOOLS Allen: 1.5mm, 2.0mm, 2.5mm, 3.0mm  | Pliers  | Scissors  | Side Cutters  | Hobby Knife  | Reamer (HUDY #107600)  |
|---|---|---|--|--|---|

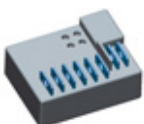
EQUIPMENT INCLUDED

| | | |
|---|---|--|
| Silicone Shock Oil  | Grease  | Turnbuckle Tool  |
|---|---|--|

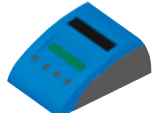
EQUIPMENT REQUIRED

| | | | | | |
|---|---|---|--|---|---|
| Transmitter  | Receiver  | Steering Servo  | Electric Motor  | Pinion Gear and Setscrew  | Speed Controller  |
| 190mm Bodyshell  | 6-cell Battery Pack (Inline)  | Lexan Paint  | Battery Charger  | Fibre Tape  | Tires & Inserts  |

0. KIT (FACTORY PRE-ASSEMBLED)

COLOR INDICATIONS

At the beginning of each section is an exploded view of the parts to be assembled. There is also a list of all the parts and part numbers that are related to the assembly of that section.

The part descriptions are color-coded to make it easier for you to identify the source of a part. Here are what the different colors mean:

STYLE A - indicates parts that are included in the bag marked for the section.

STYLE B - indicates parts that were set aside in Section 0.

STYLE C - indicates parts that are already assembled from previous steps.

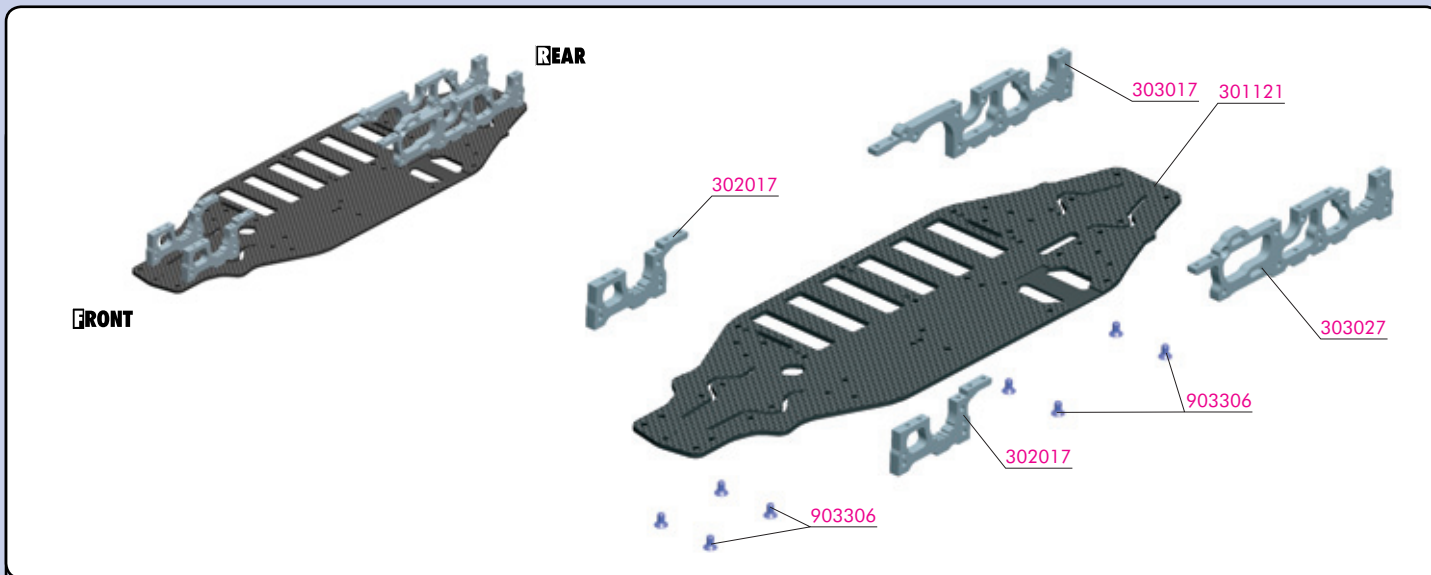

KIT

| | | | |
|---------|--|---------|-------------------------|
| 30 1121 | T2 CHASSIS 2.5MM GRAPHITE - MULTI-FLEX TECHNOLOGY™ | 90 3306 | HEX SCREW SFH M3x6 (10) |
| 30 2017 | T2 ALU SUSP. ADJUST. BULKHEAD FRONT LOWER | | |
| 30 3017 | T2 ALU SUSP. ADJUST. BULKHEAD REAR LOWER RIGHT | | |
| 30 3027 | T2 ALU SUSP. ADJUST. BULKHEAD REAR LOWER LEFT | | |

The XRAY T2 comes partially pre-assembled. Before starting assembly, disassemble the chassis parts, noting the position and orientation of the parts, particularly the bulkheads. Keep the parts, including the screw hardware, close at hand. In the assembly steps that follow, each section begins with a parts list. Parts indicated with **STYLE B** are from the previously disassembled chassis parts in section 0.

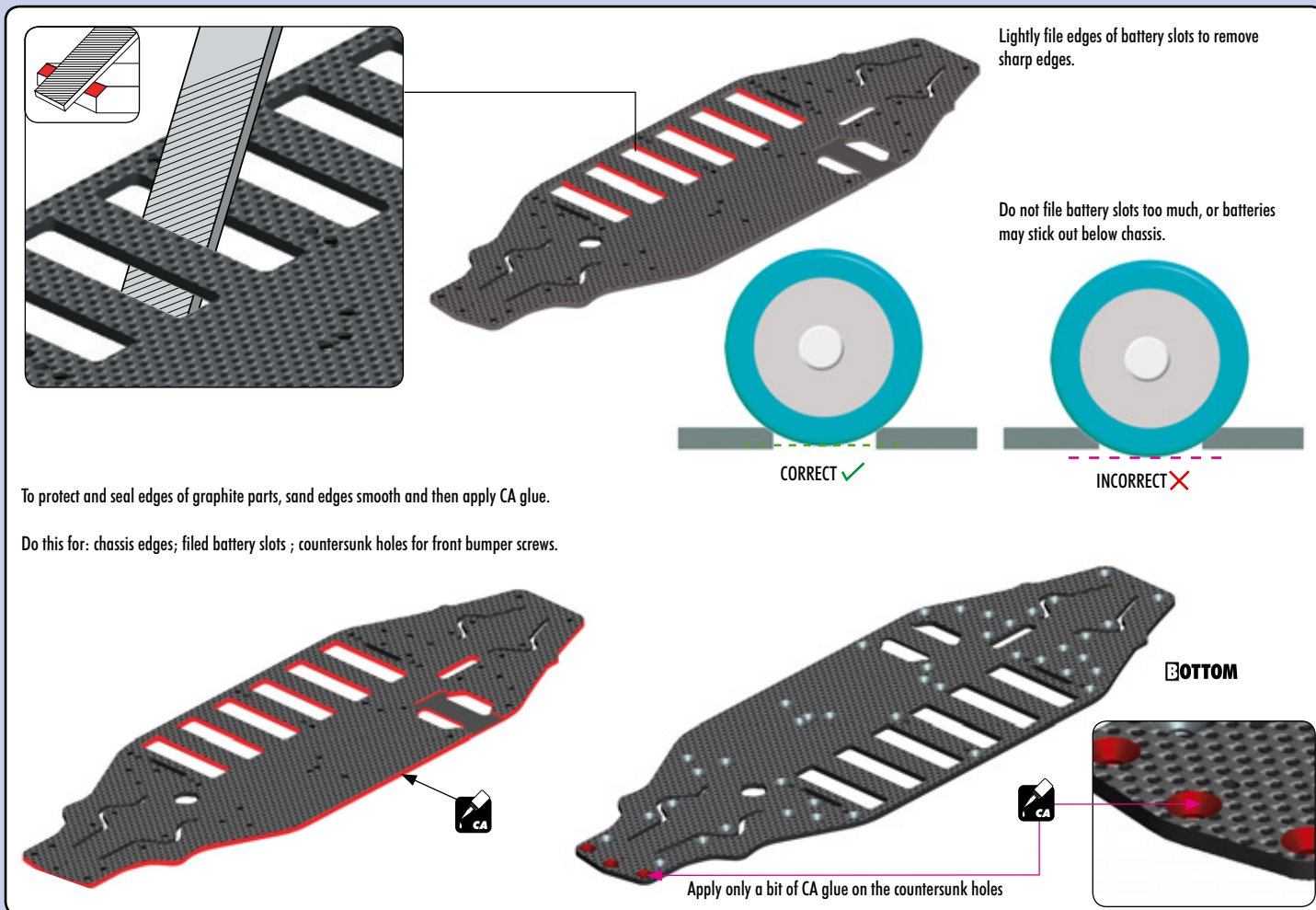

1. BALL DIFFERENTIAL & FRONT MULTI-DIFF™

01.2 BALL DIFFERENTIAL

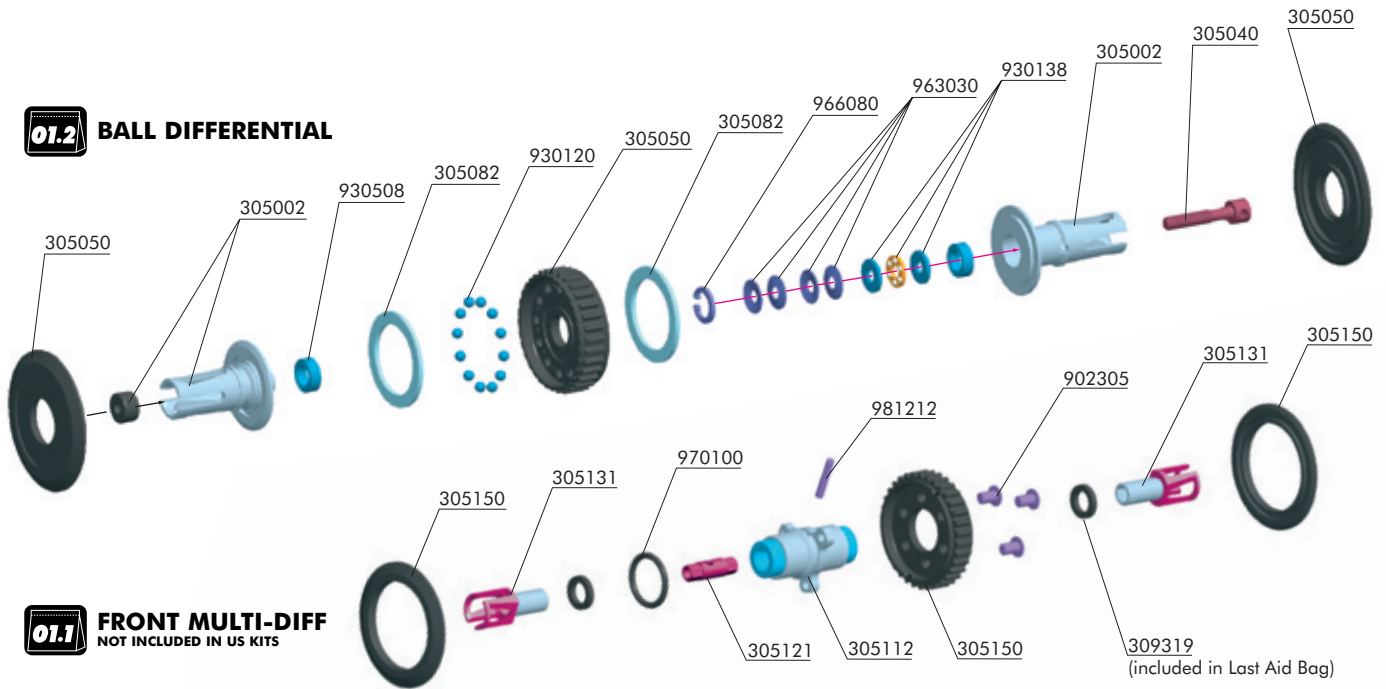

01.1 FRONT MULTI-DIFF NOT INCLUDED IN US KITS

BAG

01.1

01.2

- 30 5002 ALU BALL DIFF. WITH LABYRINTH COVERS™
- 30 5040 SCREW FOR EXTERNAL DIFF ADJUSTMENT - HUDY SPRING STEEL
- 30 5050 DIFF PULLEY 34T WITH LABYRINTH DUST COVERS
- 30 5082 DIFF WASHER 17x23x1 (2)
- 30 5102 XRAY MULTI-DIFF™ T1FK'05, T2
- 30 5112 MULTI-DIFF MAIN AXLE T1FK'05, T2
- 30 5121 MULTI-DIFF LOCKING AXLE - HUDY SPRING STEEL
- 30 5131 INNER DRIVESHAFT ADAPTER - HUDY SPRING STEEL (2)
- 30 5150 TIMING BELT PULLEY 34T

- 30 9319 UNIVERSAL SET OF PLASTIC SHIMS (included in Last Aid Bag)
- 90 2305 HEX SCREW SH M3x5 (10)
- 93 0120 CARBIDE BALL 2.4 MM (12)
- 93 0138 CARBIDE BALL-BEARING AXIAL F3-8 3x8x3.5
- 93 0508 BALL-BEARING MR85ZZ 5x8x2.5 (2)
- 96 3030 CONE WASHER ST 3x8x0.5 (10)
- 96 6080 CH-CLIP 8 (10)
- 97 0100 O-RING 10x1.5 (10)
- 98 1212 PIN 2x11.8 (10)

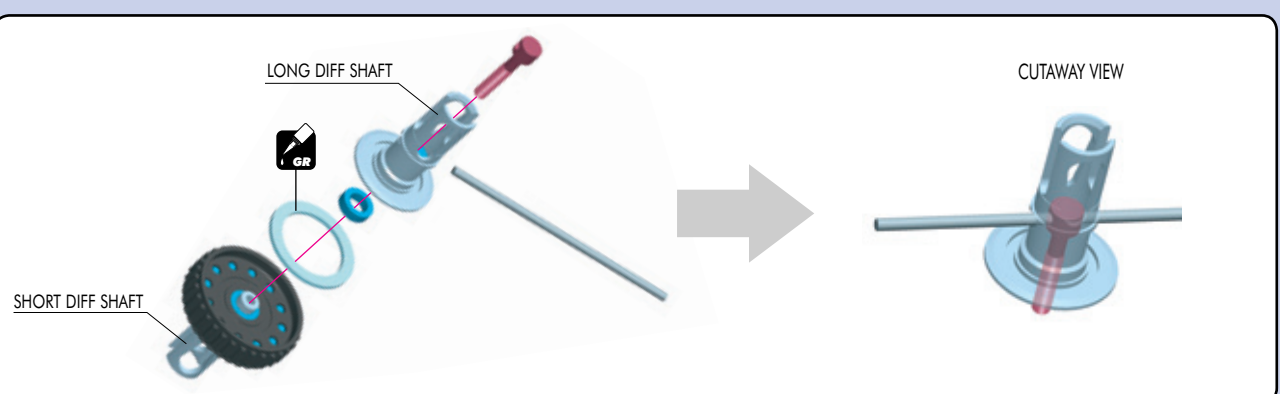
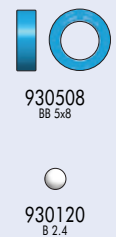
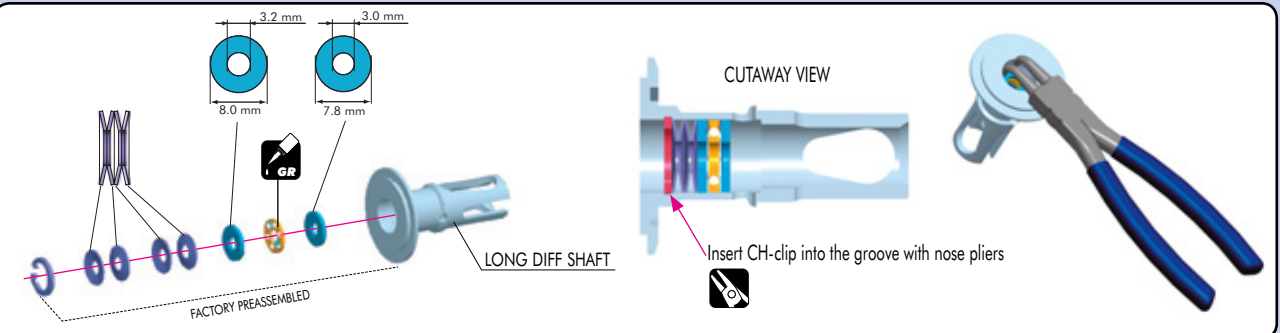

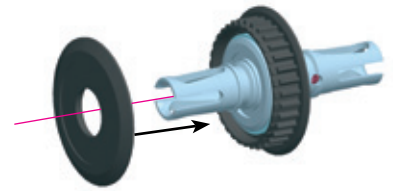
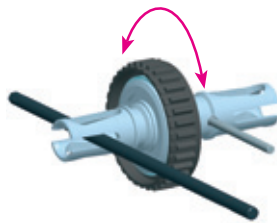
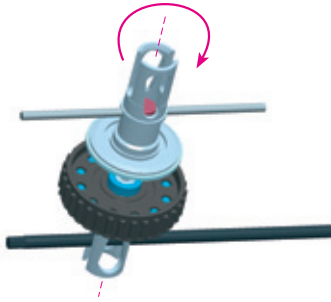

**DO NOT TIGHTEN THE DIFF COMPLETELY
THE DIFF MUST BE BROKEN IN PROPERLY !**

IMPORTANT: When you build the differential, do not tighten it fully initially; the differential needs to be broken in properly. When you build the diff tighten it very gently. When you put the diff in the car and complete the assembly, run the car for a few minutes, tighten the diff a little bit, and then recheck the diff. Repeat this process several times until you have the diff tightened to the point you want it. Final adjustments should ALWAYS be made with the diff in the car and on the track.

FRONT MULTI-DIFF™ (not included in US kits)



902305
SH M3x5



309319
SHIM 6x9x2

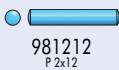

981212
P 2x12



970100
O 10x1.5

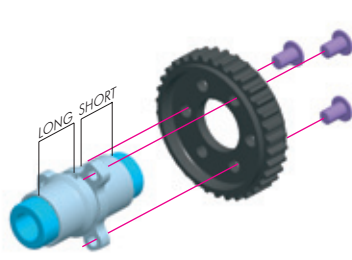

Apply one-way lube



In case of excessive play use composite shims included in the Last Aid bag.

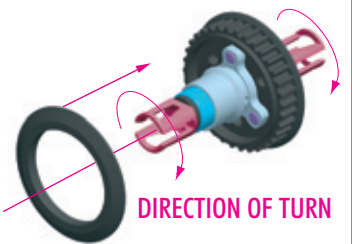

FRONT MULTI-DIFF™ SETTINGS

STANDARD ONE-WAY

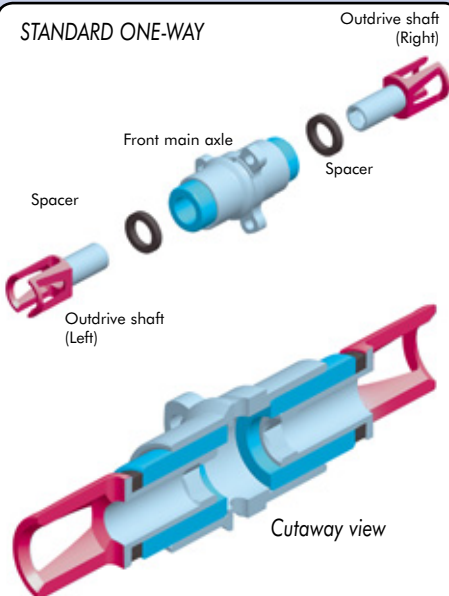

Outdrive shafts (left and right) are not connected to each other, nor to front main axle.

Off-power:

Outdrive shafts rotate forward independently of each other and front main axle.

On-power:

Both outdrive shafts rotate with front main axle (locked in one-way bearings)

Best used when...

traction is high, the car leans towards off-power understeer and the track does not require braking for the corners. Will give maximum off-power steering and increase efficiency (more runtime). Best suited to a smooth driving style.

SOLID ONE-WAY

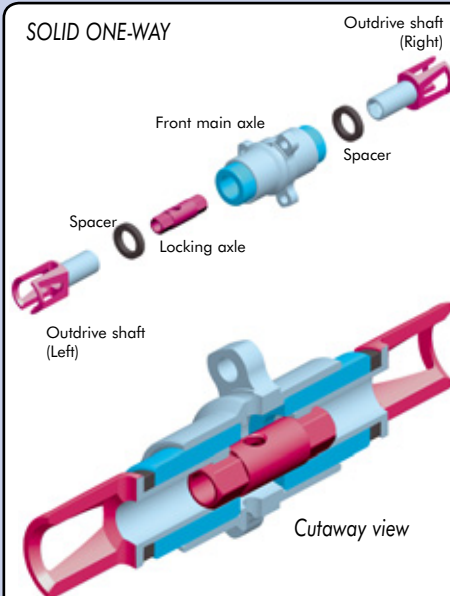

Both outdrive shafts (left and right) are connected together by internal locking axle, but are not connected to front main axle.

Off-power:

Both connected outdrive shafts rotate forward together (but independent of front main axle).

On-power:

Both outdrive shafts rotate with front main axle (locked in one-way bearings).

Best used when...

traction is medium to high and the track does not require braking for the corners. Will give good off-power steering and efficiency.

FULL-TIME SOLID AXLE

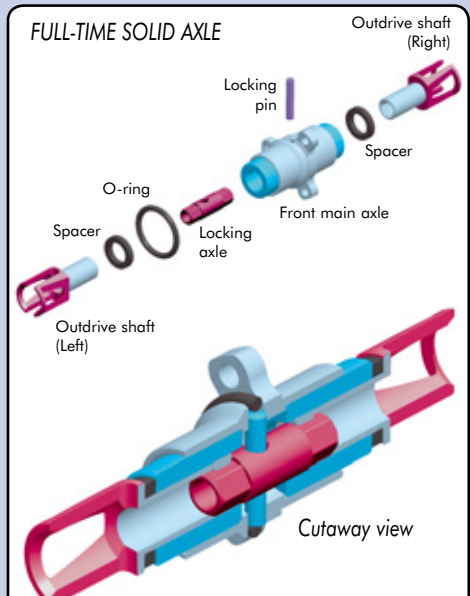

Both outdrive shafts (left and right) are connected to front main axle by internal locking axle and locking pin.

Off-power and on-power:

Both outdrive shafts rotate with front main axle.

Best used when...

traction is low to medium, the car leans towards off-power oversteer and/or the track requires braking for the corners. Will give less off-power steering and efficiency (less runtime). Best suited to an aggressive driving style.

2. FRONT & REAR SUSPENSION

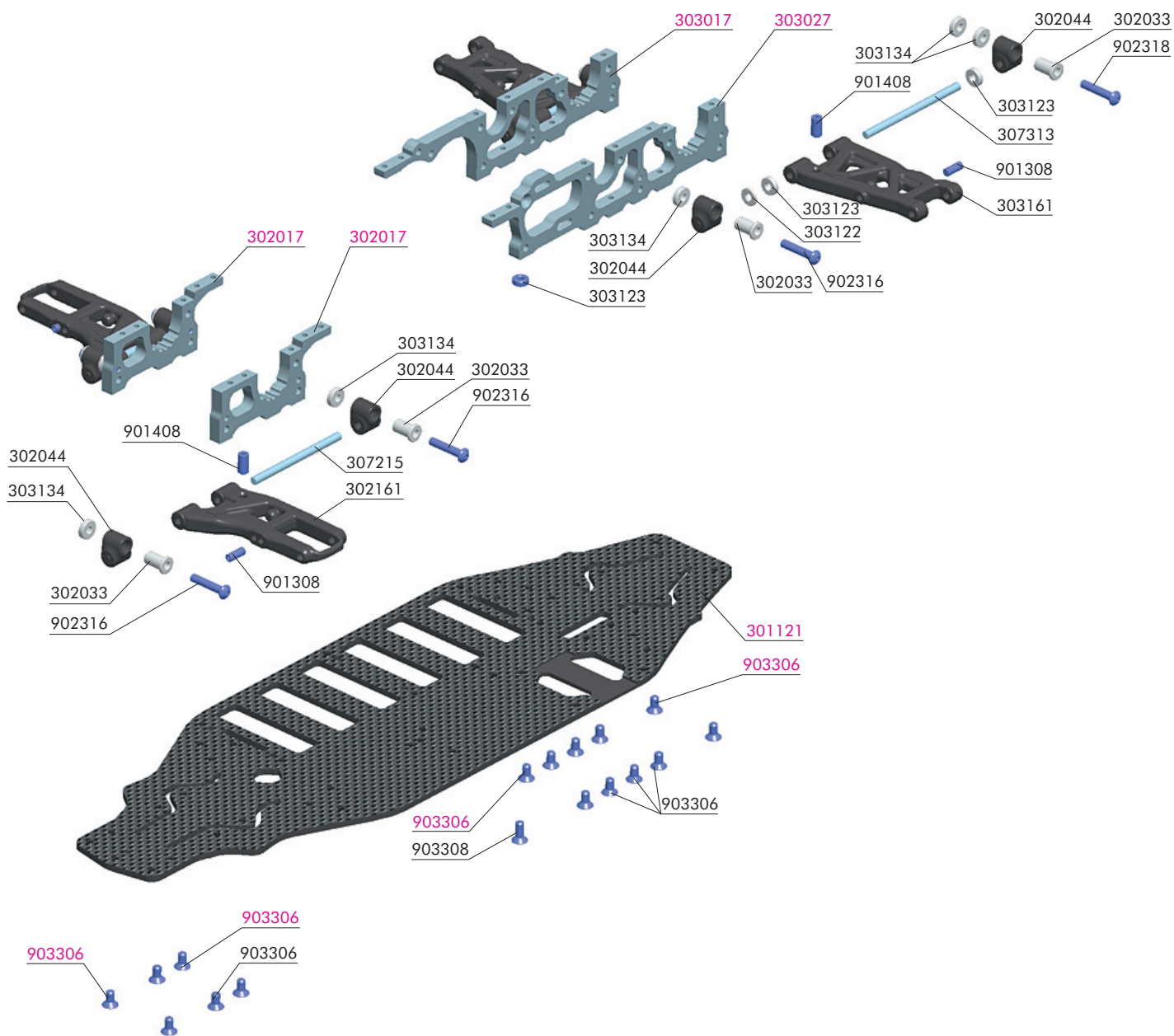

BAG

02

30 2033 T2 ALU NUT FOR SUSPENSION HOLDER (2)
 30 2044 T2 LOWER SUSPENSION HOLDERS (2+2+2)
 30 2161 T2 FRONT SUSPENSION ARM
 30 3122 ALU SHIM 3x6x1.0MM (10)
 30 3123 ALU SHIM 3x6x2.0MM (10)
 30 3134 ALU SHIM FOR LOWER SUSP. HOLDER 3x7.5x1.5 (10)
 30 3161 T2 REAR SUSPENSION ARM
 30 7215 T2 FRONT SUSPENSION PIVOT PIN (2)
 30 7313 T2 REAR SUSPENSION PIVOT PIN (2)

90 1308 HEX SCREW SB M3x8 (10)
 90 1408 HEX SCREW SB M4x8 (10)
 90 2316 HEX SCREW SH M3x16 (10)
 90 2318 HEX SCREW SH M3x18 (10)
 90 3306 HEX SCREW SFH M3x6 (10)
 90 3308 HEX SCREW SFH M3x8 (10)

30 1121 T2 CHASSIS 2.5MM GRAPHITE - MULTI-FLEX TECHNOLOGY™
 30 2017 T2 ALU SUSP. ADJUST. BULKHEAD FRONT LOWER
 30 3017 T2 ALU SUSP. ADJUST. BULKHEAD REAR LOWER RIGHT
 30 3027 T2 ALU SUSP. ADJUST. BULKHEAD REAR LOWER LEFT
 90 3306 HEX SCREW SFH M3x6 (10)

2. FRONT & REAR SUSPENSION



903306
SFH M3x6



903308
SFH M3x8

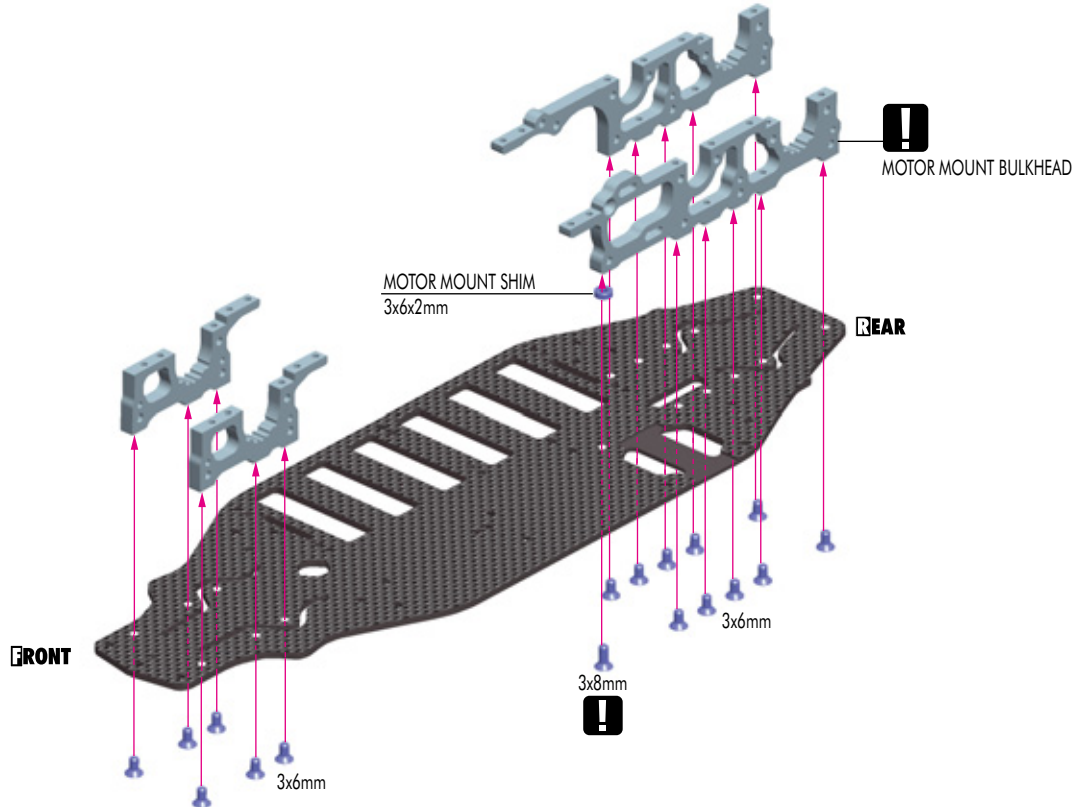

901308
SB M3x8



901408
SB M4x8

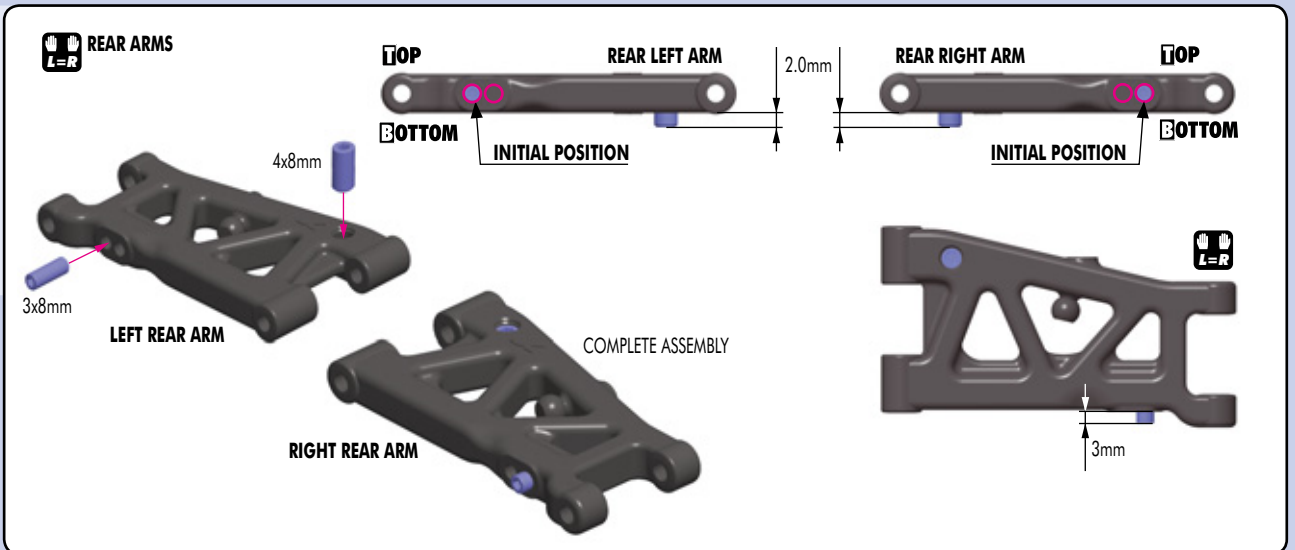

901308
SB M3x8



901408
SB M4x8

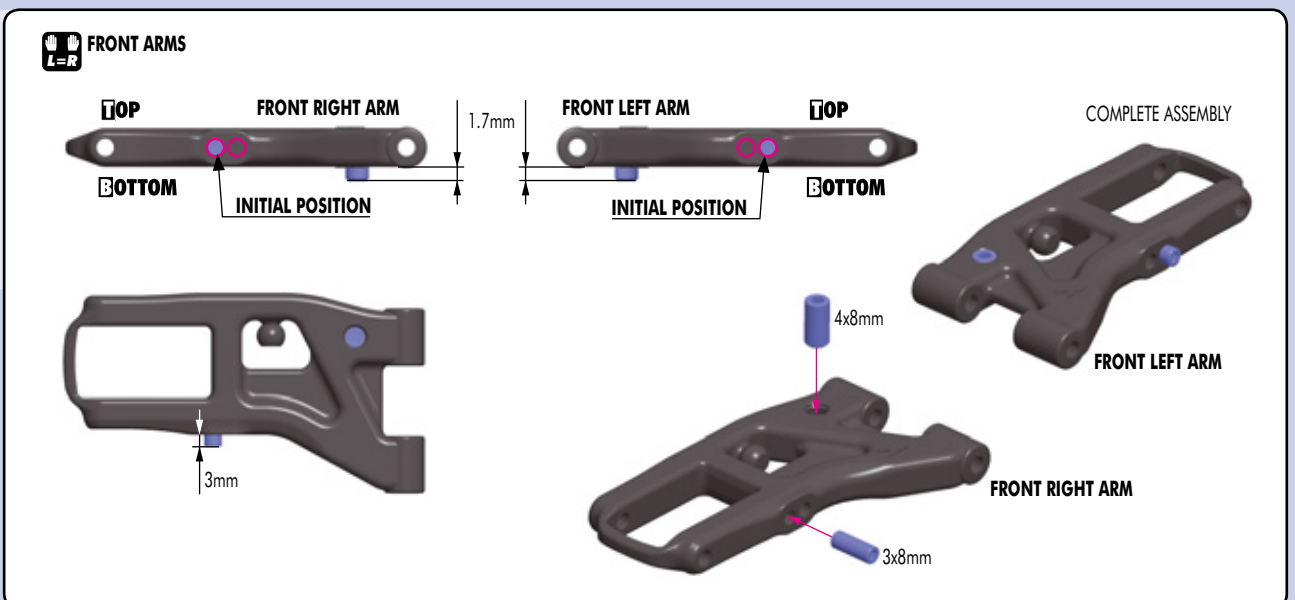

2. FRONT & REAR SUSPENSION

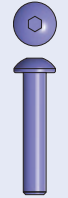

902316
SH M3x16



902318
SH M3x18

REAR RIGHT ARM

REAR LEFT ARM

REAR

3x7.5x1.5mm

3x6x1mm

3x6x2mm

3x16mm

3x7.5x1.5mm

3x18mm

DETAIL

DETAIL

Use these suspension holders for initial assembly

Roll Center Position: **-0.75mm**

Roll Center Position: **0mm**
Standard Setting

Roll Center Position: **+0.75mm**

51.5 mm

2x **1:1**



902316
SH M3x16

FRONT LEFT ARM

FRONT RIGHT ARM

FRONT

3x7.5x1.5mm

3x16mm

3x7.5x1.5mm

3x16mm

DETAIL

DETAIL

Use these suspension holders for initial assembly

Roll Center Position: **-0.75mm**

Roll Center Position: **0mm**
Standard Setting

Roll Center Position: **+0.75mm**

47.5 mm

2x **L=R**

3. CENTRAL TRANSMISSION

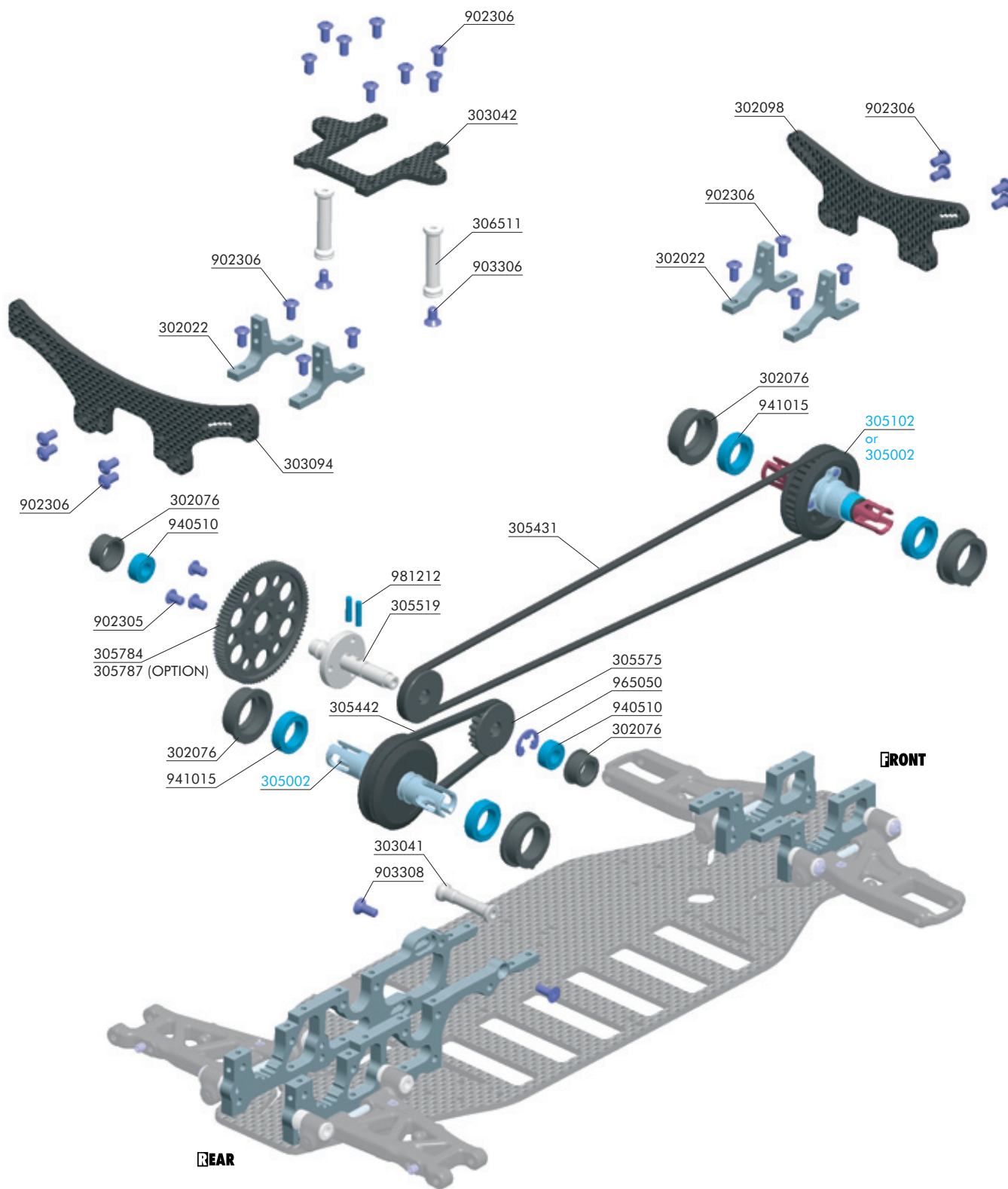

BAG

03

- 30 2022 T2 ALU UPPER CLAMP FOR BULKHEADS (2)
- 30 2076 T2 SET OF COMPOSITE HUBS FOR BULKHEADS (4+2)
- 30 2098 T2 SHOCK TOWER FRONT 3.0MM GRAPHITE
- 30 3041 T2 ALU REAR BULKHEAD BRACE
- 30 3042 T2 REAR UPPER DECK 2.5MM GRAPHITE - CNC MACHINED
- 30 3094 T2 SHOCK TOWER REAR 3.0MM GRAPHITE
- 30 5431 HIGH-PERFORMANCE KEVLAR DRIVE BELT FRONT 3 x 507 MM
- 30 5442 HIGH-PERFORMANCE KEVLAR DRIVE BELT REAR 3 x 180 MM
- 30 5519 T2 ALU SOLID LAYSHAFT
- 30 5575 FIXED PULLEY 20T (2)
- 30 5784 SPUR GEAR "H" 84T / 48
- 30 5787 SPUR GEAR "H" 87T / 48 (OPTION)
- 30 5790 SPUR GEAR "H" 90T / 48 (OPTION)
- 30 6511 T2 ALU TOP DECK MOUNT REAR (2)

- 90 2305 HEX SCREW SH M3x5 (10)
- 90 2306 HEX SCREW SH M3x6 (10)
- 90 3306 HEX SCREW SFH M3x6 (10)
- 90 3308 HEX SCREW SFH M3x8 (10)
- 94 0510 HIGH-SPEED BALL-BEARING 5x10x4 RUBBER SEALED (2)
- 94 1015 HIGH-SPEED BALL-BEARING 10x15x4 RUBBER SEALED (2)
- 96 5050 E-CLIP 5 (10)
- 98 1212 PIN 2x12 (10)

- 30 5002 ALU BALL DIFF. WITH LABYRINTH COVERS™
- 30 5102 XRAY MULTI-DIFF T1FK'05, T2

3. CENTRAL TRANSMISSION



902305
SH M3x5



965050
CS

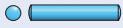

981212
P 2x12

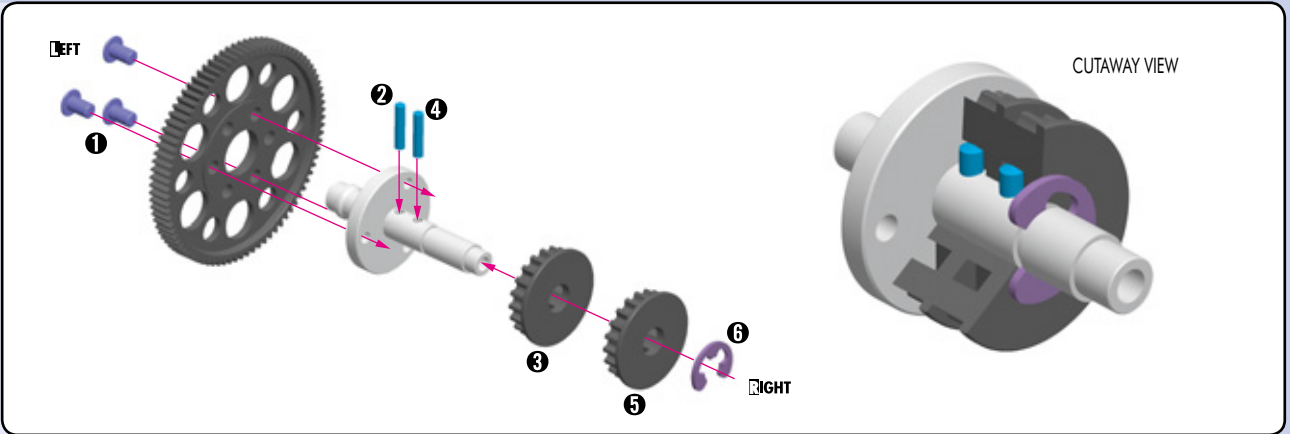

940510
BB 5x10x4



941015
BB 10x15x4

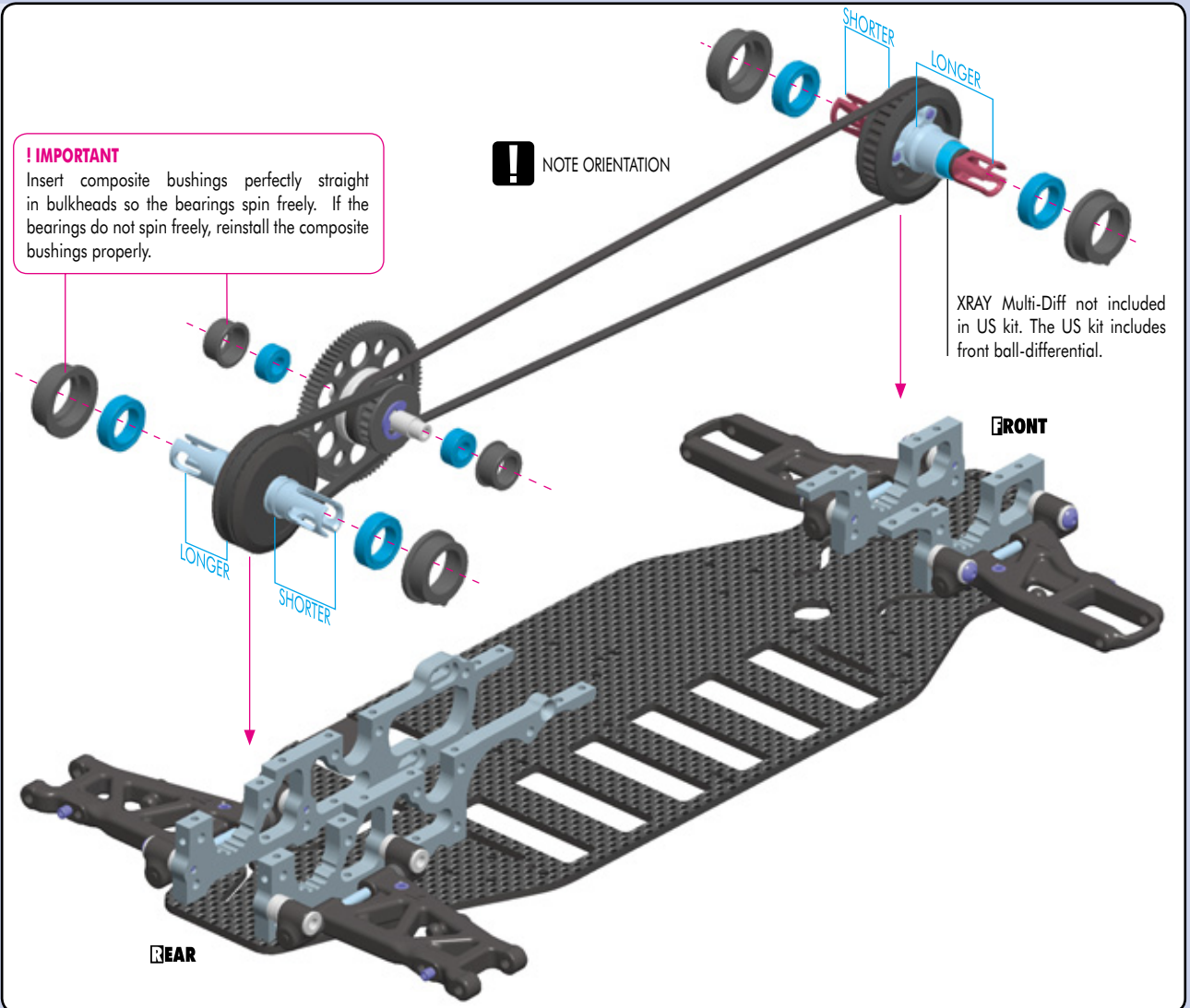

FRONT BELT TENSION ADJUSTMENT



FRONT

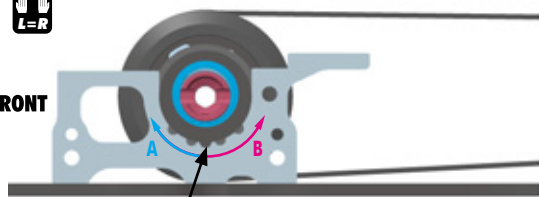

INITIAL POSITION:
PLACE TAB IN THIS NOTCH

TO LOOSEN FRONT BELT:
Rotate both front nylon hubs in arrow direction (A)

TO TIGHTEN FRONT BELT:
Rotate both front nylon hubs in arrow direction (B)

REAR BELT TENSION ADJUSTMENT



REAR

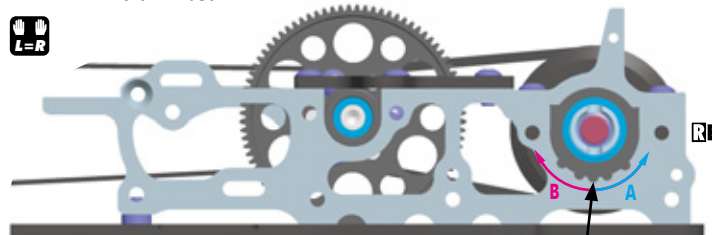

INITIAL POSITION:
PLACE TAB IN THIS NOTCH

TO LOOSEN REAR BELT:
Rotate both front nylon hubs in arrow direction (A)

TO TIGHTEN REAR BELT:
Rotate both front nylon hubs in arrow direction (B)

3. CENTRAL TRANSMISSION

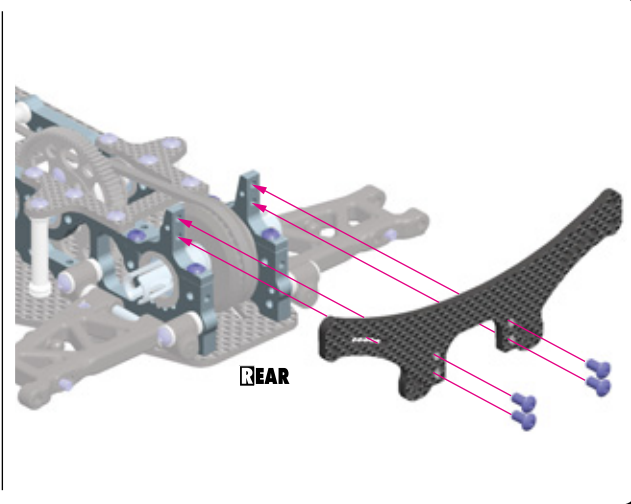
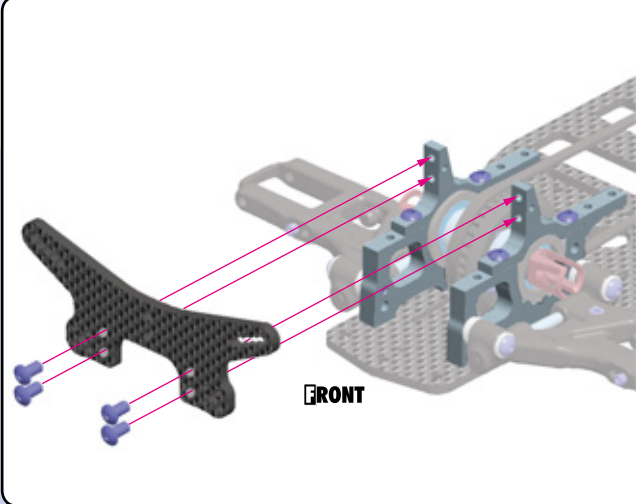
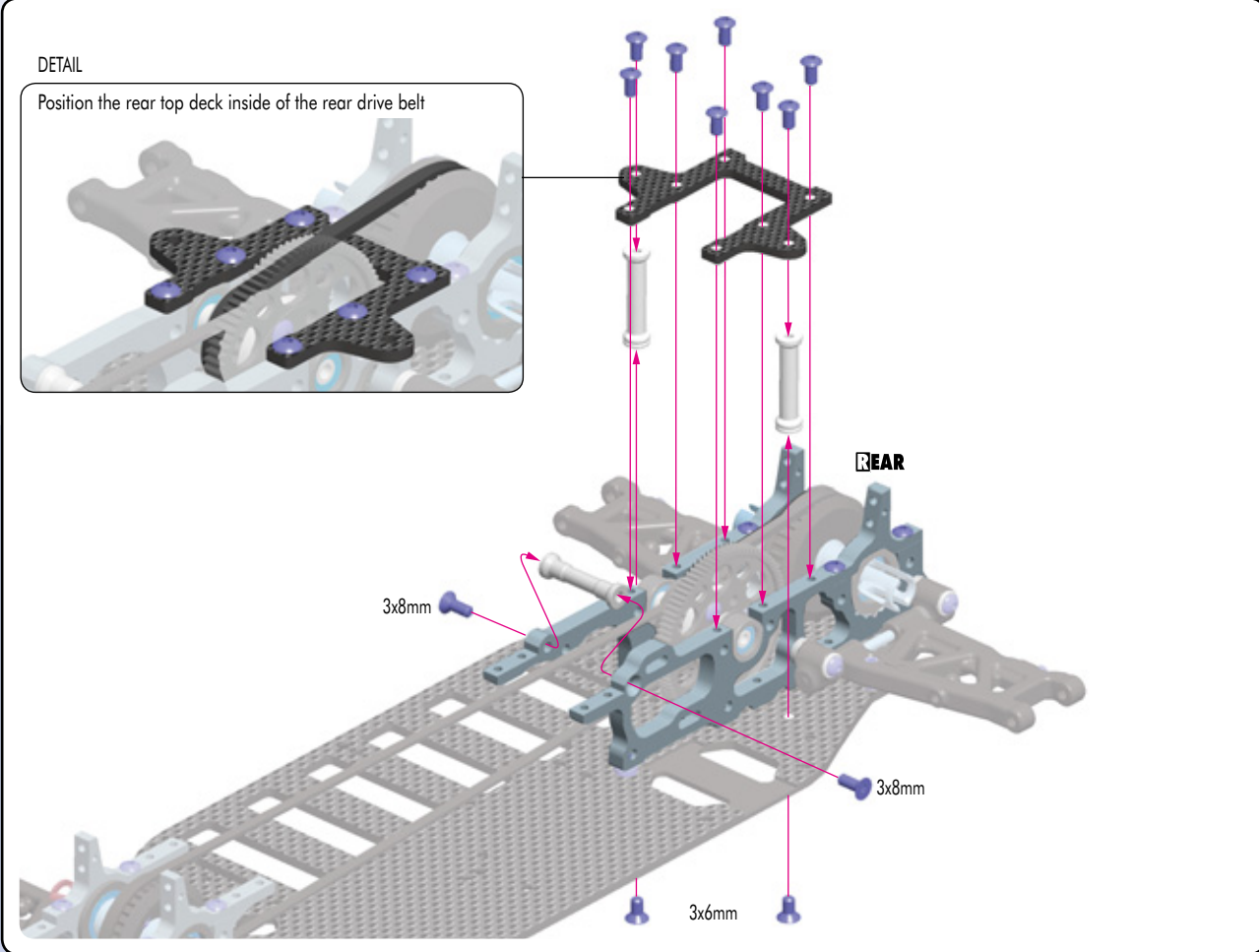
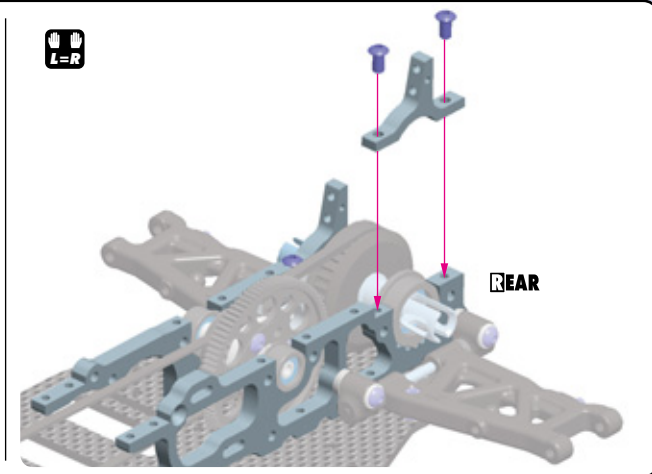
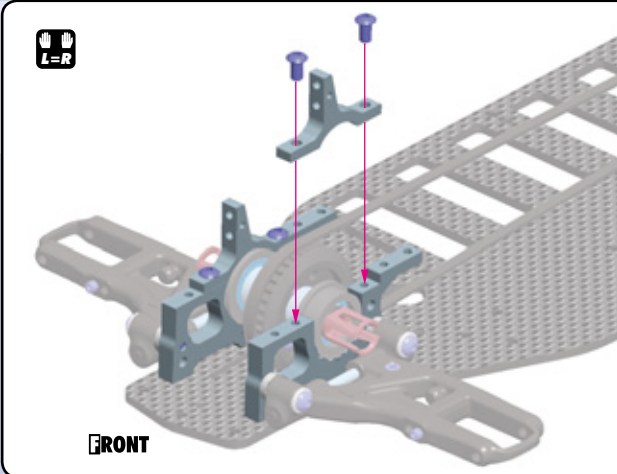

4. FRONT & REAR TRANSMISSION

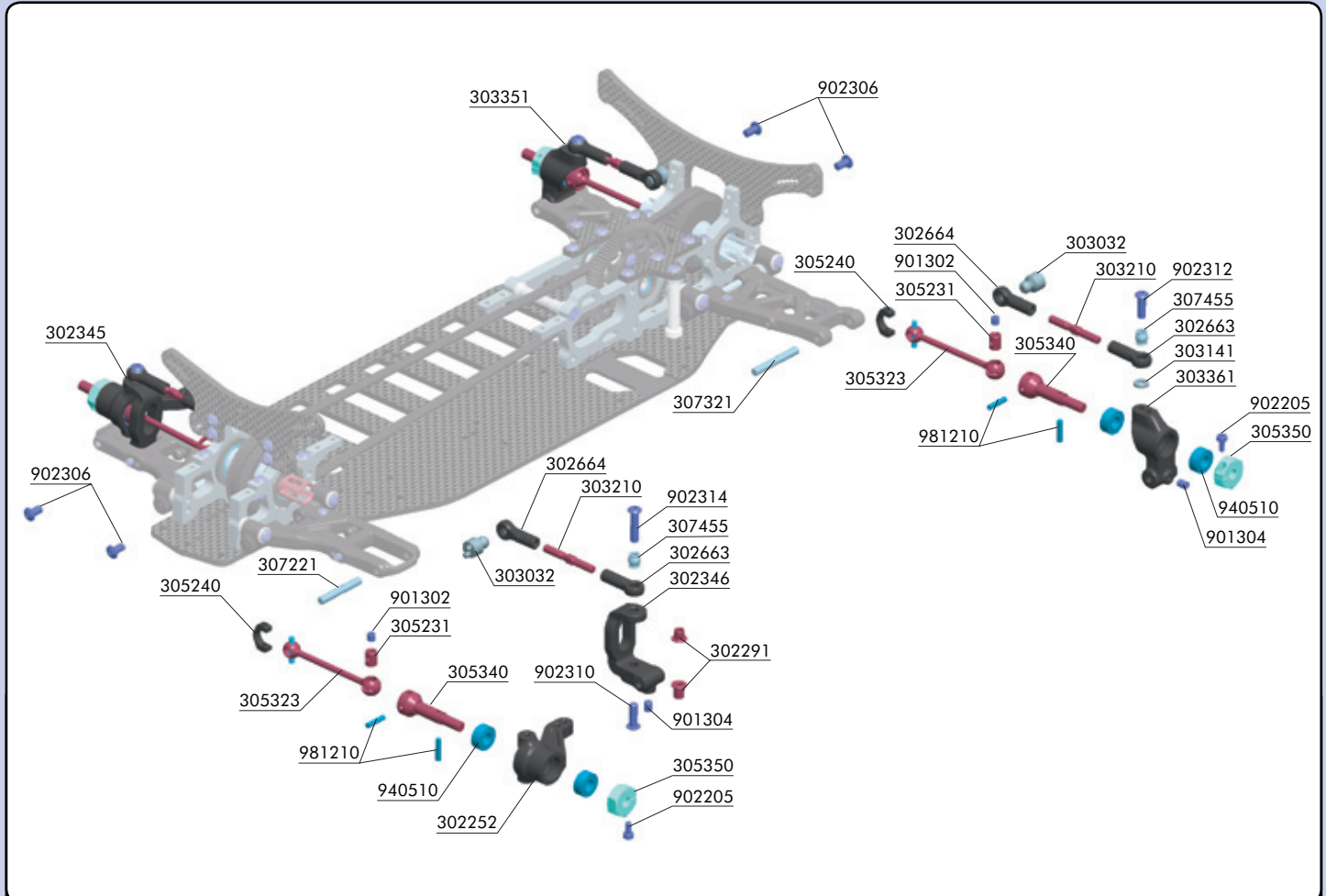

BAG

04

| | | | |
|---------|---|---------|--|
| 30 2252 | T2 COMPOSITE STEERING BLOCK | 30 5350 | T2 ALU WHEEL HUB (2) |
| 30 2291 | T2 STEEL STEERING BUSHING (2+2) | 30 7221 | T2 FRONT ARM PIVOT PIN (2) |
| 30 2345 | T2 COMPOSITE C-HUB FRONT BLOCK, RIGHT - 4° DEG. | 30 7321 | T2 REAR ARM PIVOT PIN (2) |
| 30 2346 | T2 COMPOSITE C-HUB FRONT BLOCK, LEFT - 4° DEG. | 30 7455 | T2 PIVOT BALL 5.0 MM DOUBLE BEVEL SHOULDERS (10) |
| 30 2663 | T2 BALL JOINT 5 MM - OPEN (8) | | |
| 30 2664 | T2 BALL JOINT 5 MM UNIDIRECTIONAL - OPEN (4) | 90 1302 | HEX SCREW SB M3x2.5 (10) |
| 30 3032 | T2 ALU QUICK ROLL-CENTER HOLDER™ 4.9MM (2) | 90 1304 | HEX SCREW SB M3x4 (10) |
| 30 3141 | ALU SHIM 3x5x1.0MM (10) | 90 2205 | HEX SCREW SH M2x5 (10) |
| 30 3210 | REAR TURNBUCKLE L/R 25 MM - HUDY SPRING STEEL (2) | 90 2306 | HEX SCREW SH M3x6 (10) |
| 30 3351 | T2 COMPOSITE UPRIGHT 1° OUTBOARD TOE-IN - RIGHT | 90 2310 | HEX SCREW SH M3x10 (10) |
| 30 3361 | T2 COMPOSITE UPRIGHT 1° OUTBOARD TOE-IN - LEFT | 90 2312 | HEX SCREW SH M3x12 (10) |
| 30 5231 | T2 DRIVE SHAFT COUPLING - HUDY SPRING STEEL | 90 2314 | HEX SCREW SH M3x14 (10) |
| 30 5240 | DRIVE SHAFT REPLACEMENT PLASTIC CAP 3 MM (4) | 94 0510 | HIGH-SPEED BALL-BEARING 5x10x4 RUBBER SEALED (2) |
| 30 5323 | T2 DRIVE SHAFT - HUDY SPRING STEEL | 98 1210 | PIN 2x10 (10) |
| 30 5340 | T2 DRIVE AXLE - HUDY SPRING STEEL | | |



901302
SB M3x2.5



981210
P 2x10

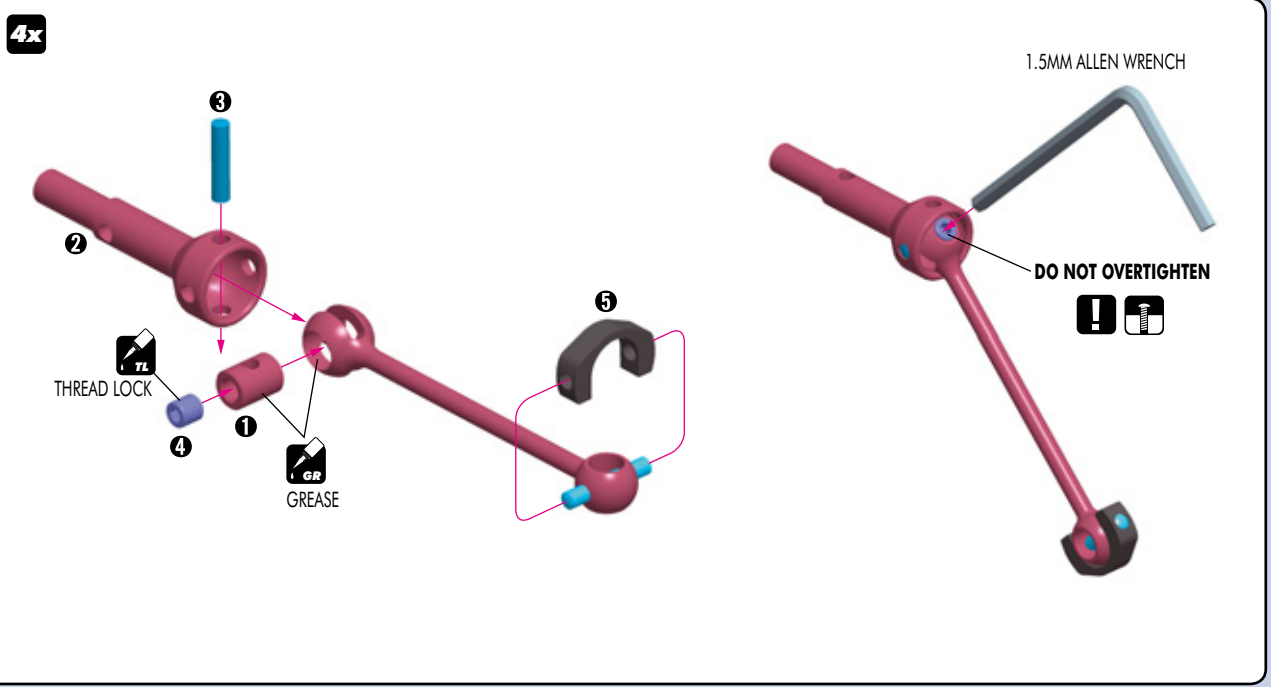

4. FRONT & REAR TRANSMISSION

2x

902205 SH M2x5

940510 BB 5x10x4

981210 P 2x12

1R = RIGHT SUSPENSION BLOCK 1° OUTBOARD TOE-IN
1L = LEFT SUSPENSION BLOCK 1° OUTBOARD TOE-IN

COMPLETE ASSEMBLY

2x

902205 SH M2x5

940510 BB 5x10x4

981210 P 2x12

LEFT STEERING BLOCK = RIGHT STEERING BLOCK

L=R

COMPLETE ASSEMBLY

L=R

2x

902310 SH M3x10

SHORT

LONG

RIGHT C-HUB "4R"

RIGHT

LEFT

COMPLETE ASSEMBLY

LEFT C-HUB "4L"

4x

SPECIAL UNIDIRECTIONAL BALL-JOINT WITH MOLDED DOT

MOLDED DOT

52.5 mm

53.0 mm

FRONT RIGHT = FRONT LEFT

REAR RIGHT = REAR LEFT

1:1

1:1

4x

4. FRONT & REAR TRANSMISSION



303141
SHIM 3x5x1



307455
PB 5mm



901304
SB M3x4

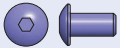

902306
SH M3x6



902312
SH M3x12

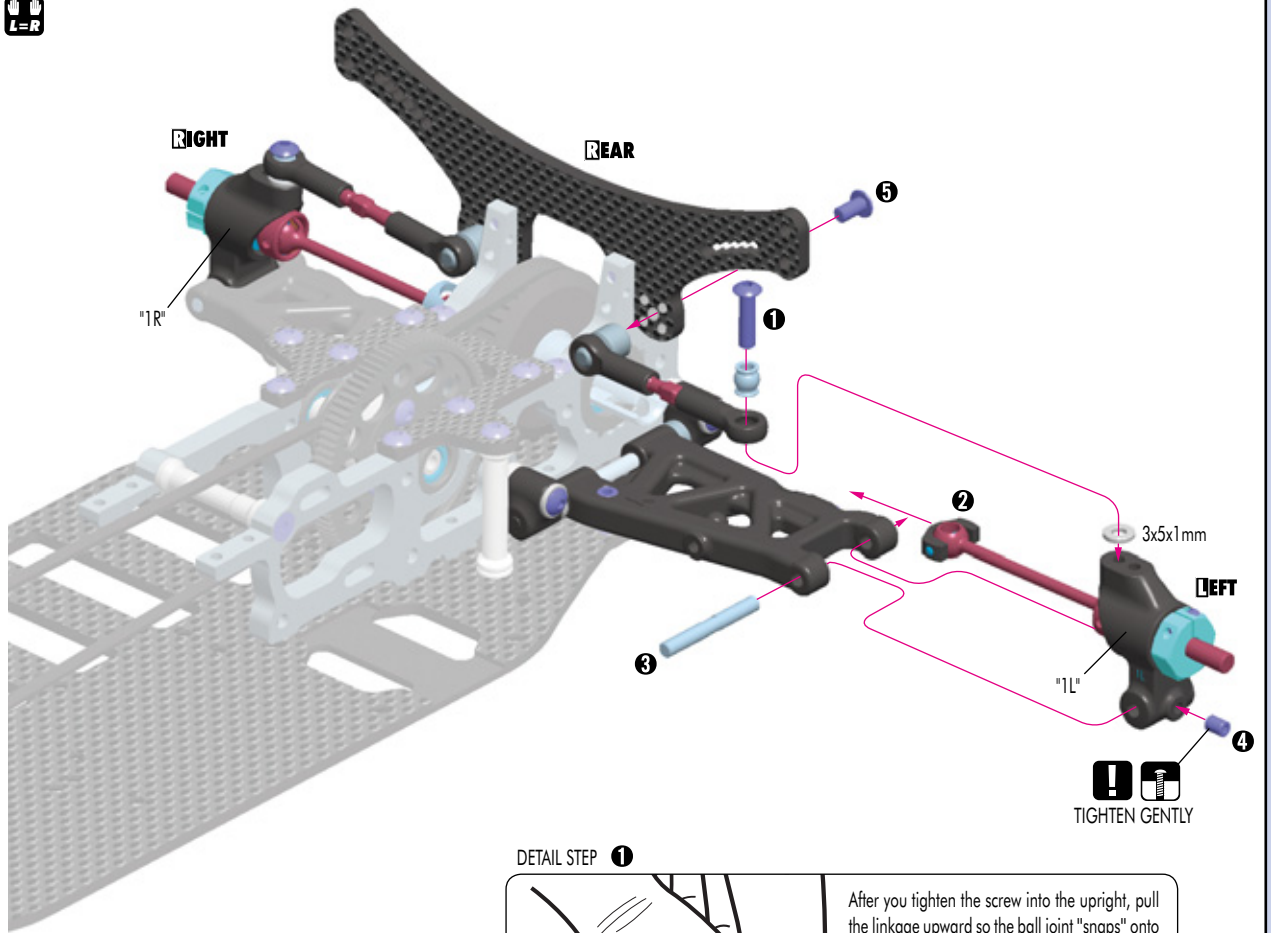

DETAIL STEP 1

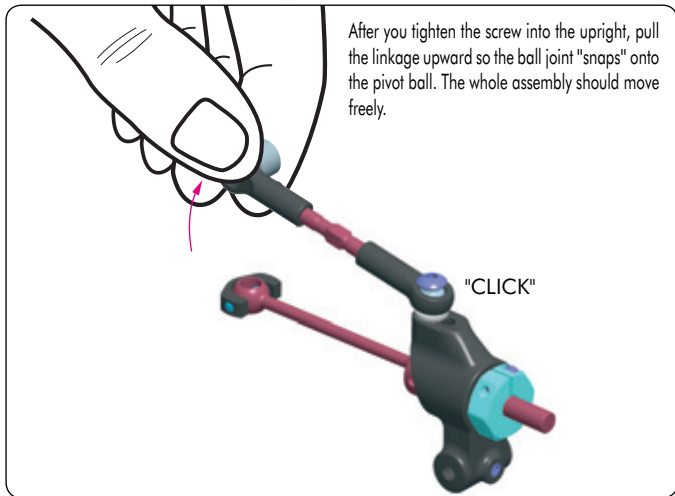

1:1 2x

25 mm

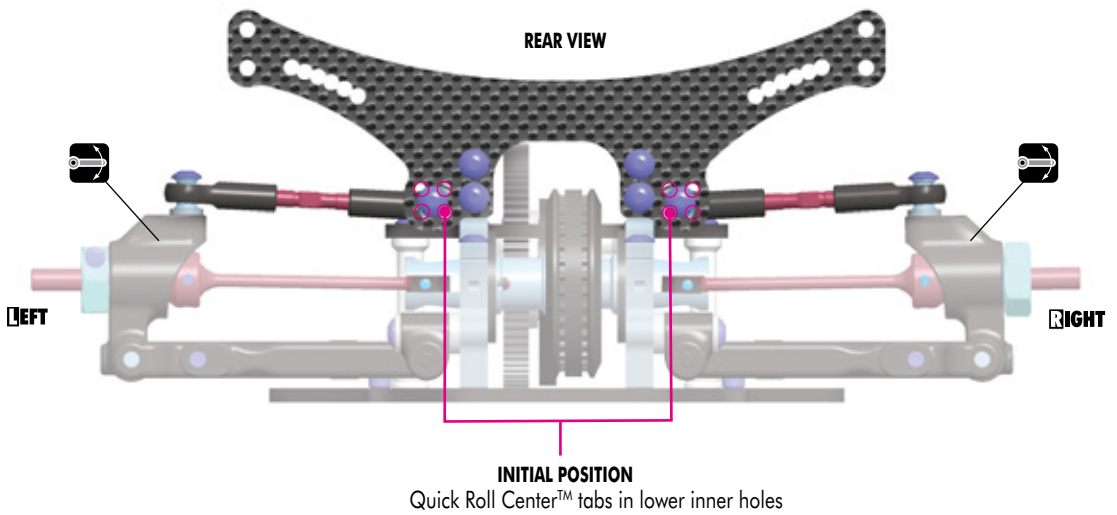

4. FRONT & REAR TRANSMISSION



307455
PB 5mm



901304
SB M3x4



902306
SH M3x6



902314
SH M3x14

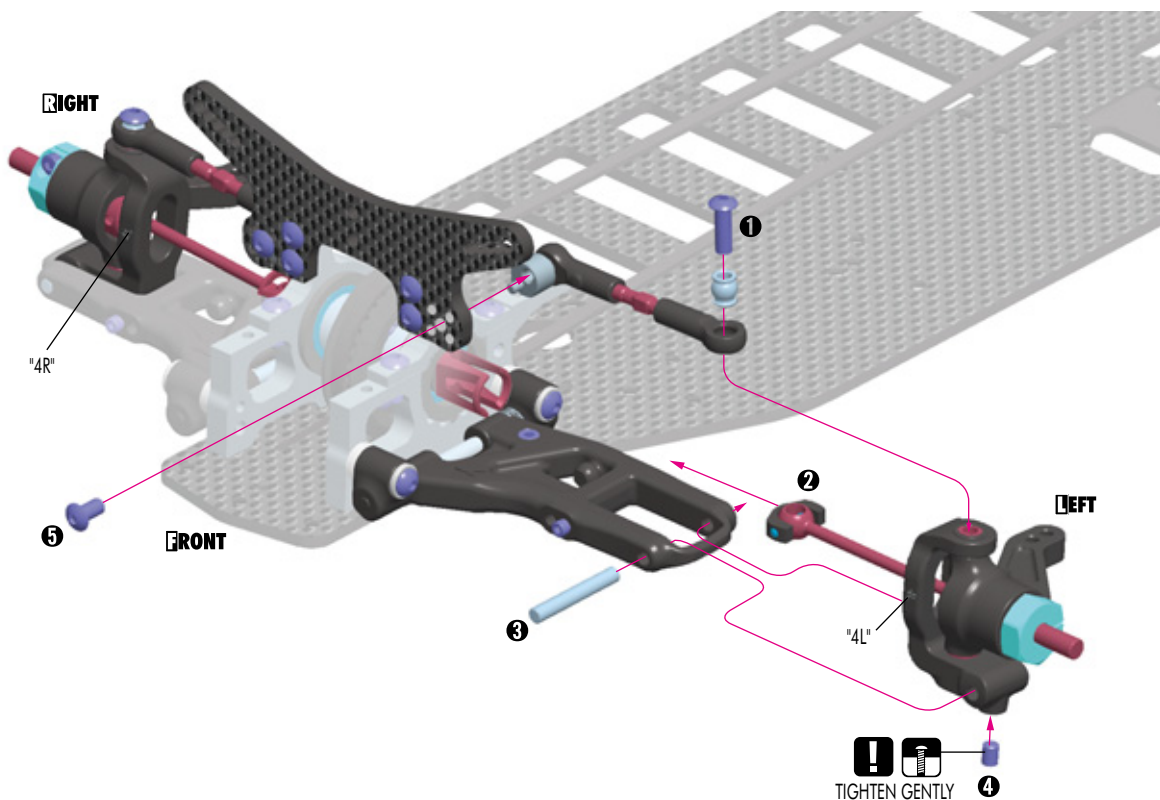

DETAIL STEP 1

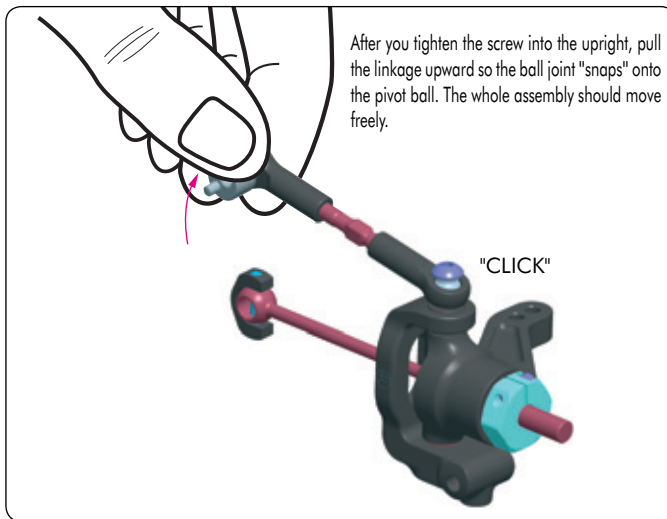

1:1 2x

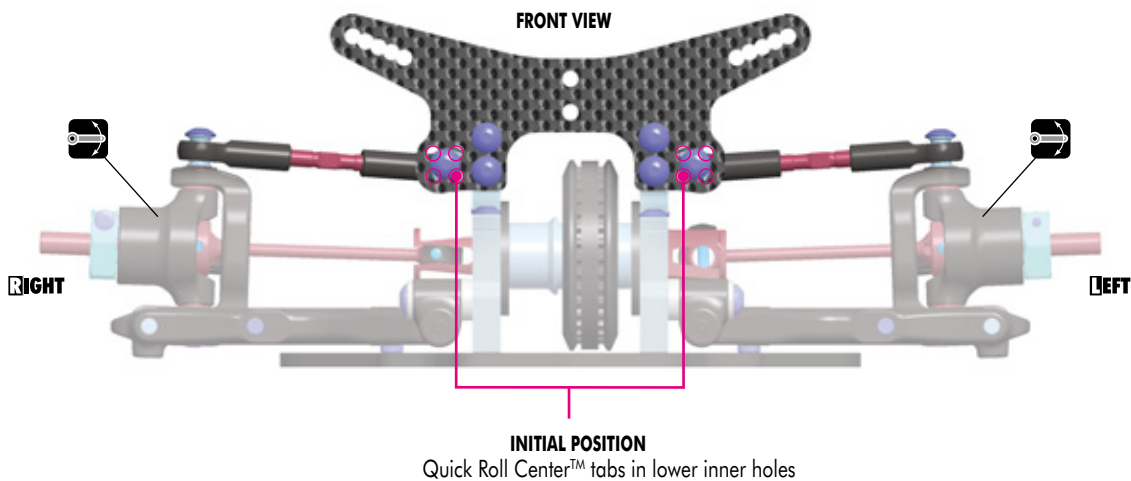
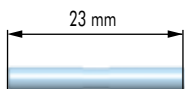

5. STEERING

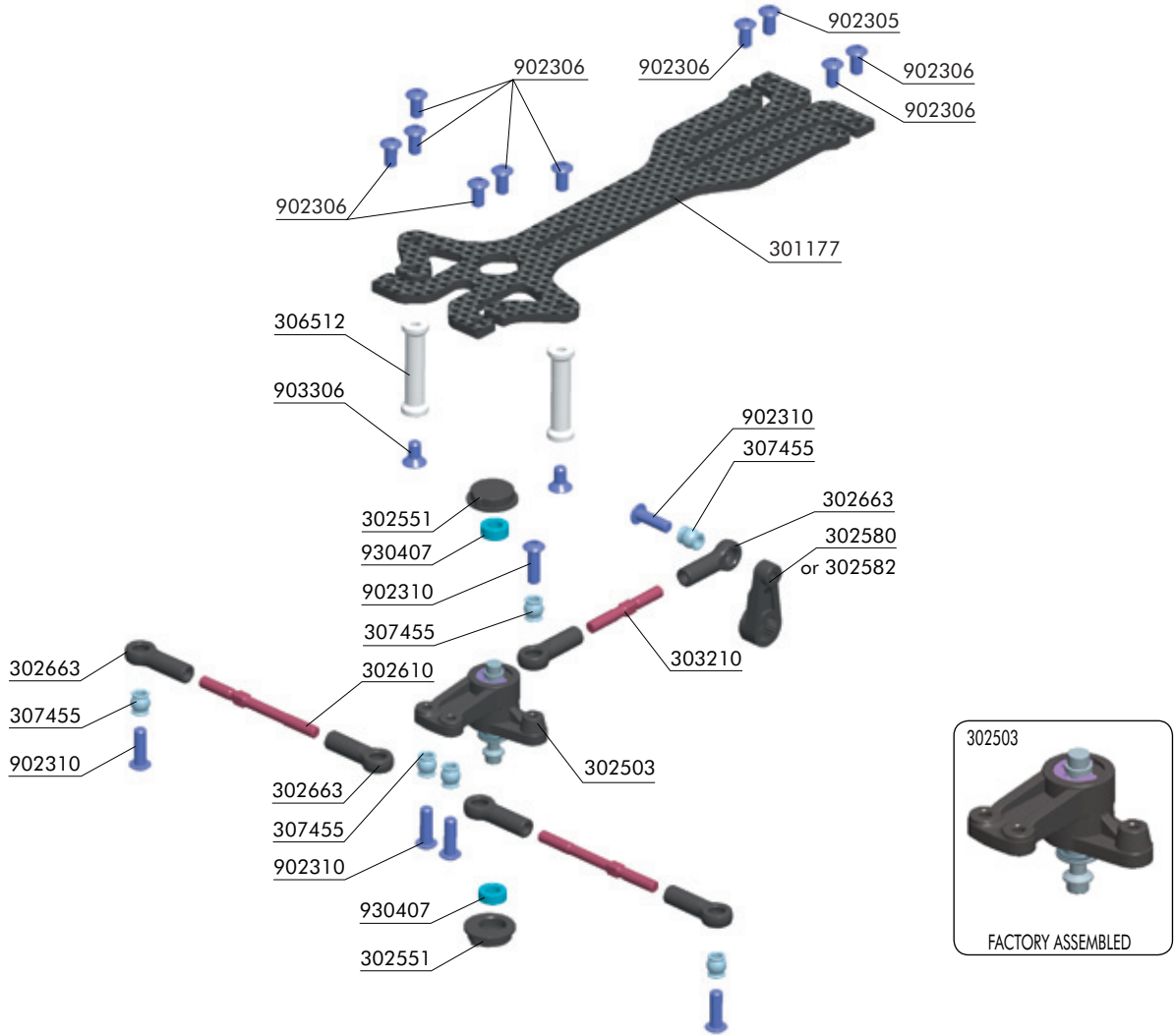

BAG

05

| | | | |
|---------|--|---------|--|
| 30 1177 | T2 ADJ. UPPER DECK 2.5MM GRAPHITE - MULTI-FLEX TECHNOLOGY™ | 30 6512 | T2 ALU TOP DECK MOUNT FRONT (2) |
| 30 2503 | T2 SERVO SAVER (SET) | 30 7455 | T2 PIVOT BALL 5.0 MM DOUBLE BEVEL SHOULDERS (10) |
| 30 2551 | SERVO SAVER PLASTIC COVER - ECCENTRIC (2) | | |
| 30 2580 | COMPOSITE SERVO HORN - KO, JR, AIRTRONICS, MULTIPLEX | 90 2305 | HEX SCREW SH M3x5 (10) |
| 30 2582 | COMPOSITE SERVO HORN - FUTABA, ROBE | 90 2306 | HEX SCREW SH M3x6 (10) |
| 30 2610 | ADJ. TURNBUCKLE M3 L/R 40 MM - HUDY SPRING STEEL (2) | 90 2310 | HEX SCREW SH M3x10 (10) |
| 30 2663 | T2 BALL JOINT 5 MM - OPEN (8) | 90 3306 | HEX SCREW SFH M3x6 (10) |
| 30 3210 | REAR TURNBUCKLE L/R 25 MM - HUDY SPRING STEEL (2) | 93 0407 | BALL-BEARING MR74ZZ 4x7x2.5 (2) |



307455
PB 5mm



902310
SH M3x10

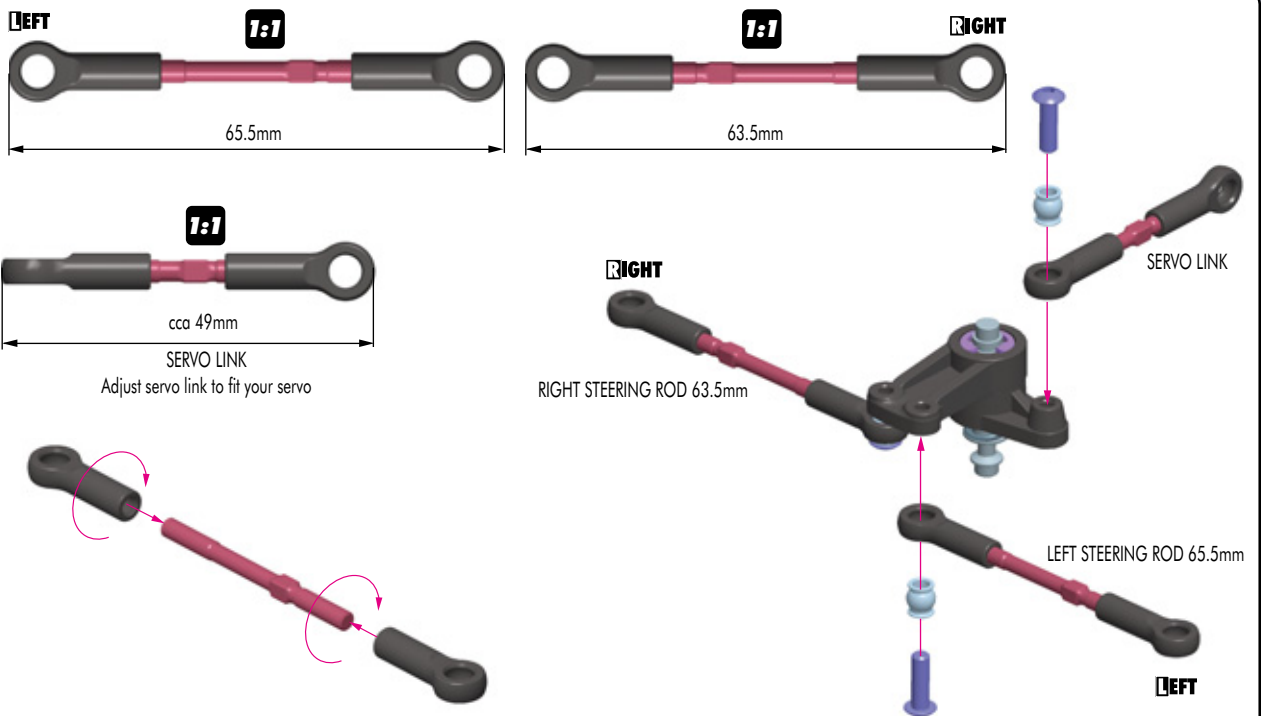

5. STEERING



307455
PB 5mm



902310
SH M3x10

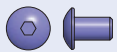
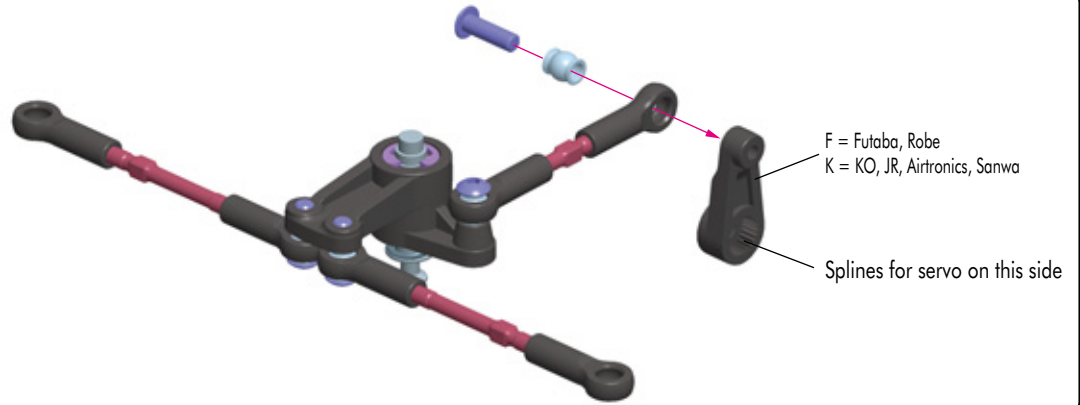

902305
SH M3x5

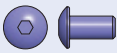

902306
SH M3x6



903306
SFH M3x6



930407
BB 4x7x2.5

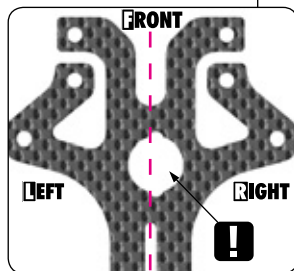
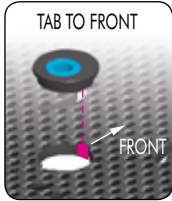
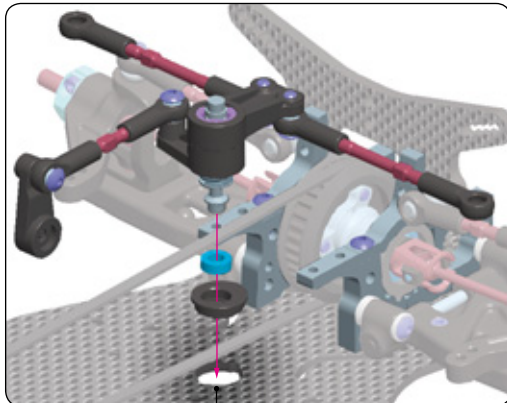

! IMPORTANT

The hole in top deck for the eccentric bearing holder is not directly along the centerline of the top deck, but rather is slightly off-center. Mount the top deck so that the off-center hole is to the RIGHT of the centerline.

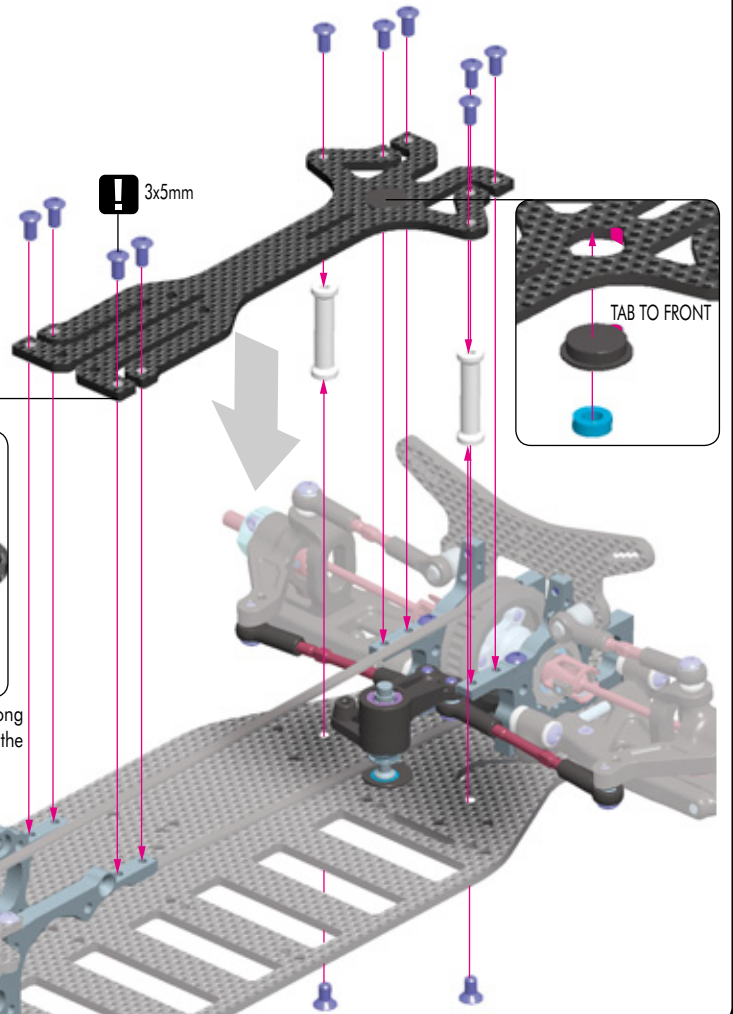

307455
PB 5mm



902310
SH M3x10

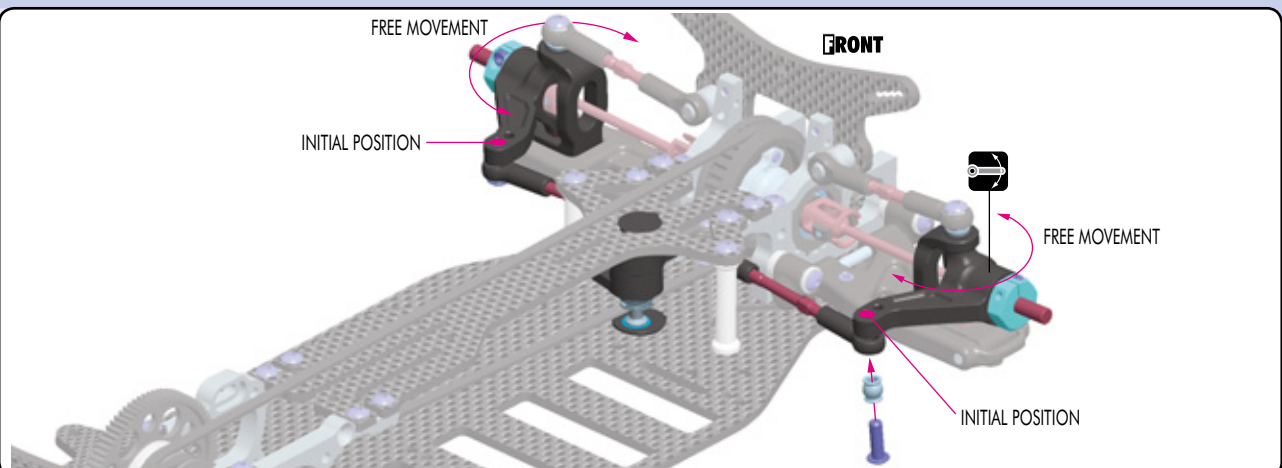

6. SHOCK ABSORBERS

ADJUSTABLE PISTONS

NON-ADJUSTABLE PISTONS

! IMPORTANT
 USE ONLY special T2 ball-joints (part #308316).
 DO NOT USE ball joints on #308330 parts tree.

| | | | | |
|--------------------|---------|--|---------|--|
| BAG | 30 3241 | BALL UNIVERSAL 5.8 MM HEX (4) | 30 8380 | ADDITIONAL XRAY ULTIMATE RACING SPRINGS (20) |
| | 30 8035 | COMPOSITE PISTONS ADJUSTABLE + NON-ADJUST. (SET 2+6) | 30 8390 | XRAY SELECTED ULTIMATE RACING SPRINGS (24) |
| | 30 8040 | SHOCK ADJ. NUT ALU + O-RING (4+4) | | |
| | 30 8080 | SHOCKABSORBER MEMBRANES (4) | 96 1032 | WASHER S 3.2 (10) |
| | 30 8090 | SHOCK FOAM INSERTS (4) | 96 5019 | E-CLIP 1.9 (10) |
| | 30 8301 | T2 XRAY SHOCK ABSORBER-SET 4-STEP - SHORT (2) | 96 5023 | E-CLIP 2.3 (10) |
| | 30 8316 | T2 SHOCK BALL JOINT - OPEN (4) | 97 0050 | O-RING 5x1 (10) |
| | 30 8330 | T2 COMPOSITE FRAME SHOCK PARTS 4-STEP - SHORT | 97 0121 | O-RING 12.1x1.6 (10) |
| | 30 8351 | T2 SHOCK CAP-NUT ALU (2) | 97 1031 | SILICONE O-RING 3.1x1.6 (10) |
| | 30 8361 | T2 HARDENED SHOCK SHAFT (2) | | |

Properly functioning shocks are very important to the performance of your car. This XRAY shock set contains parts to build four externally-adjustable or non-adjustable shocks. Both adjustable and non-adjustable shocks feature XRAY's unique keying system that positively locks the pistons to the shock rods. Carefully cut the parts from the frames, and then VERY carefully trim any excess flash with a sharp hobby knife. We recommend you use extra-fine sandpaper to gently smooth small flashing. The side walls of the pistons must be perfectly round and smooth for proper operation.

We recommend you build all four shocks simultaneously. Ensure you have a clean work area to build the shocks.

ADJUSTABLE PISTONS

Apply a drop or two of shock oil to the piston pieces. Press upper piston (A) into lower piston (B) as shown. The upper piston with holes (A) has a small tab that must exactly fit into one of the notches in lower piston (B).

Assemble FOUR adjustable shock rod assemblies by performing the following steps.

1. Press a #965023 (C 2.3) E-clip into the lower groove in the shock rod.
2. Place a #961032 (S 3.2) washer onto the shock rod atop the C-clip.
3. Press the piston assembly onto the shock rod, aligning flat in pistons with flat on the shock rod.
4. Press a #965019 (C 1.9) E-clip into the upper groove in the shock rod.
5. Apply a drop or two of shock oil to the piston rod assembly, and then insert the shock rod assembly into the shock body.

965023
C 2.3

961032
S 3.2

965019
C 1.9

NON-ADJUSTABLE PISTONS

Assemble FOUR non-adjustable piston rod assemblies by performing the following steps. Use the 3-hole non-adjustable pistons.

1. Press a #965023 (C 2.3) E-clip into the lower groove in the shock rod.
2. Press a 3-hole piston onto the shock rod, aligning flat in piston with flat on the shock rod.
3. Press a #965019 (C 1.9) E-clip into the upper groove of the shock rod.
4. Apply a drop or two of shock oil to the piston rod assembly, and then insert the shock rod assembly into the shock body.

965023
C 2.3

965019
C 1.9

1. Lubricate the inner edge of a #970121 (O 12.1x1.6) O-ring with a drop or two of shock oil. Insert it into the groove of a #308040 threaded collar.

2. Carefully thread the collar onto the shock body as shown.

Be careful not to cross-thread the collar on the shock body.

970121
O 12.1x1.6

6. SHOCK ABSORBERS



1. Insert the larger #970050 (O 5x1) O-ring onto the shock body, until it seats around the shock body extension.
2. Lubricate the small #971031 (O 3.1x1.6) O-ring with a drop or two of shock oil. Taking care not to rip or damage the O-ring, slide it over the end of the shock rod.
3. Install the end-cap onto the bottom of the shock body. Lock it in place by pressing it on, then turning it CW about 1/8 of a turn. For easy assembly, use a #183010 HUDY Shock Assembly Tool.

4x

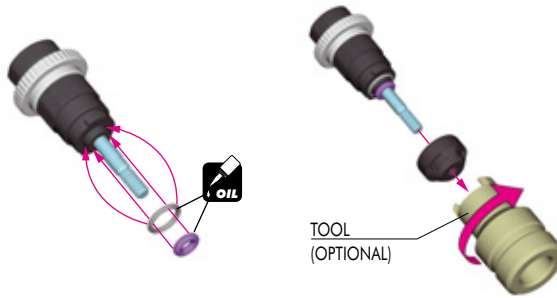

TOOL (OPTIONAL)

Grip the shock rod. Use either a shock rod clamping tool, or grip the top of the shock rod's exposed thread with side-cutting pliers.

4x

Thread the ball joint onto the shock rod until approximately 1mm of thread is exposed.

! IMPORTANT

USE ONLY special T2 ball-joints (part #308316). DO NOT USE ball joints on nylon parts tree.

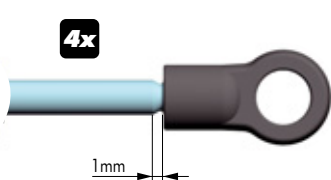

INCORRECT X



CORRECT ✓

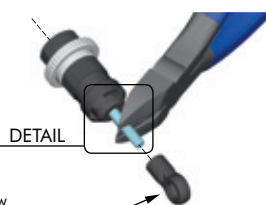

DETAIL

HINT: Pre-thread the ball joint using an M3 screw.

WARNING! Be careful not to pre-thread too far, since the ball joint may split or the plastic threads may strip out

1. Fully extend the piston rod so the piston is at the bottom of the shock body.
2. Hold the shock upright and slightly overfill the shock body with shock oil.
3. Let the oil settle and allow air bubbles to rise to the top. Slowly move the piston up and down until no more air bubbles appear. Add shock oil as necessary.
4. Pull the piston rod most of the way out of the shock body.
5. Place the rubber bladder on top of the shock body from a side. Some oil should spill out.
6. Move the piston out very slightly so the bladder seals against the top of the shock body.

4x

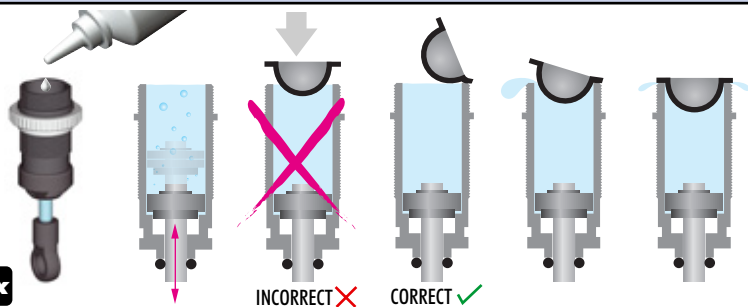

INCORRECT X

CORRECT ✓

1. Place foam insert into cavity in top mount.
2. Place top mount onto top of bladder.
3. Install and tighten alum. cap nut.

4x



Shock bleeding:

Turn the shock upside down and pull the shock rod out to full extension. Release the shock end-cap by turning it CCW and pulling it slightly away from the shock body. Let the shock "vent" for at least 10 minutes; excess oil should seep out the end of the shock body. If the shock rod doesn't retract slightly into the shock body, push it in by 1~2mm. Replace the end-cap.

Check the shock for proper operation. The shock rod must move in and out freely with only "hydraulic" dampening. The shock rod should not extend out fully (rebound) by itself when pushed in and released, nor should it be drawn into the shock body fully when extended and released. It is normal to have anywhere from 25% to 75% of rebound. If it extends out more than 75% repeat the bleeding procedure and let the shock sit for a few more minutes. Make sure that all four shocks have very similar natural rebound.

Shock length adjustment:

It is VERY important that all shocks are equal length. Fully extend the shock absorber and measure the end-to-end length; we recommend using digital calipers to give an accurate measurement. If a shock absorber is shorter or longer than others, adjust the shock length by tightening or loosening the ball joint on the shock rod.

Cutaway view of assembled shock absorber

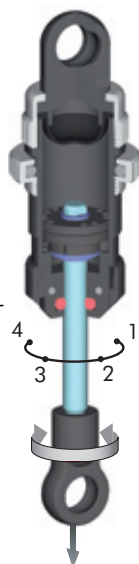

SOFTEST

HARDEST

Damping adjustment:

If you built the adjustable shocks, fully extend the shock rod and turn it slightly to lock the piston in the shock body.

Turning the shock rod fully CCW aligns 4 holes in the pistons (softest damping). Turning the shock rod fully CW aligns 1 hole in the pistons (hardest damping). The shocks have four settings, each of which can be felt by a slight "click".

Set all four shocks initially to position 3 (3 holes open).

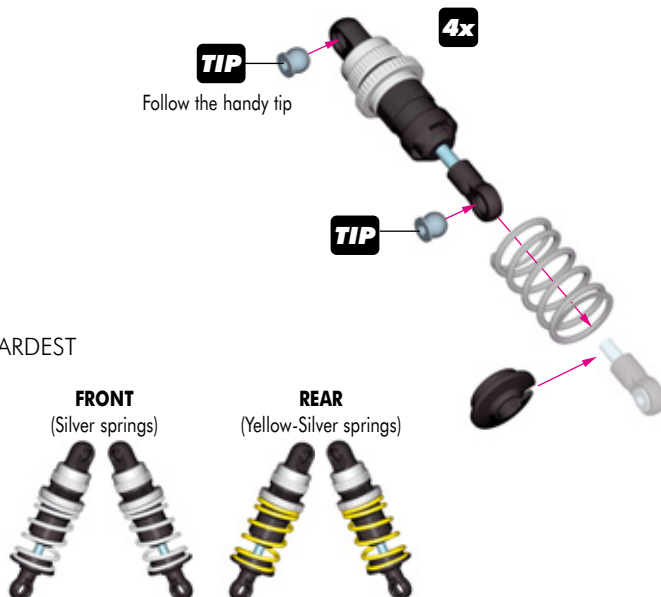

TIP

Follow the handy tip

4x

TIP

FRONT (Silver springs)

REAR (Yellow-Silver springs)

7. FRONT & REAR ASSEMBLY

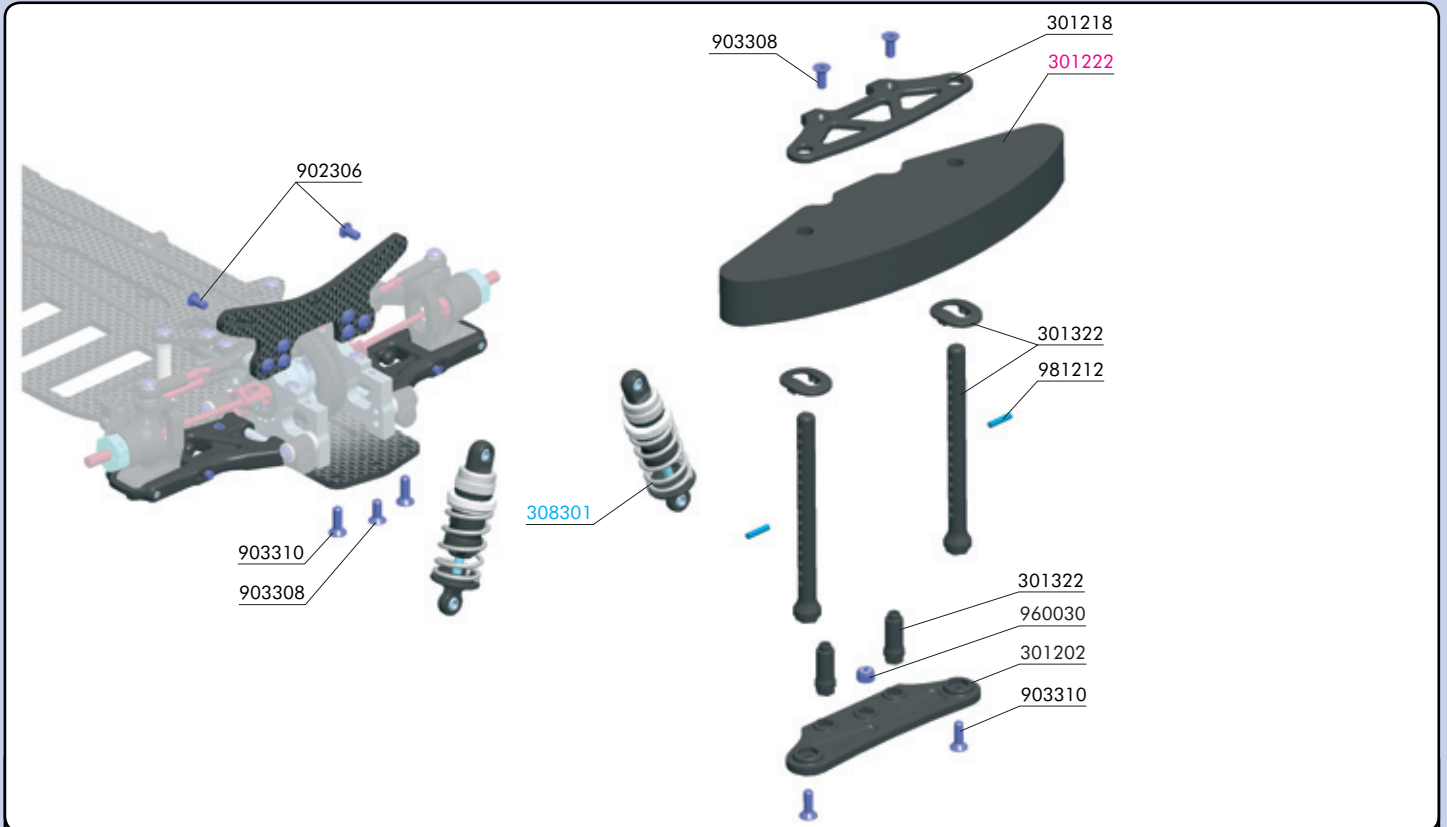

BAG

07

30 1202 T2 COMPOSITE BUMPER
 30 1218 T2 COMPOSITE UPPER HOLDER FOR BUMPER
 30 1322 T2 FRONT BODY MOUNT SET 6MM

90 2306 HEX SCREW SH M3x6 (10)
 90 3308 HEX SCREW SFH M3x8 (10)
 90 3310 HEX SCREW SFH M3x10 (10)

96 0030 NUT M3 (10)
 98 1212 PIN 2x12 (10)

30 1222 T2 FOAM BUMPER
 30 8301 T2 XRAY SHOCK ABSORBER-SET 4-STEP - SHORT (2)

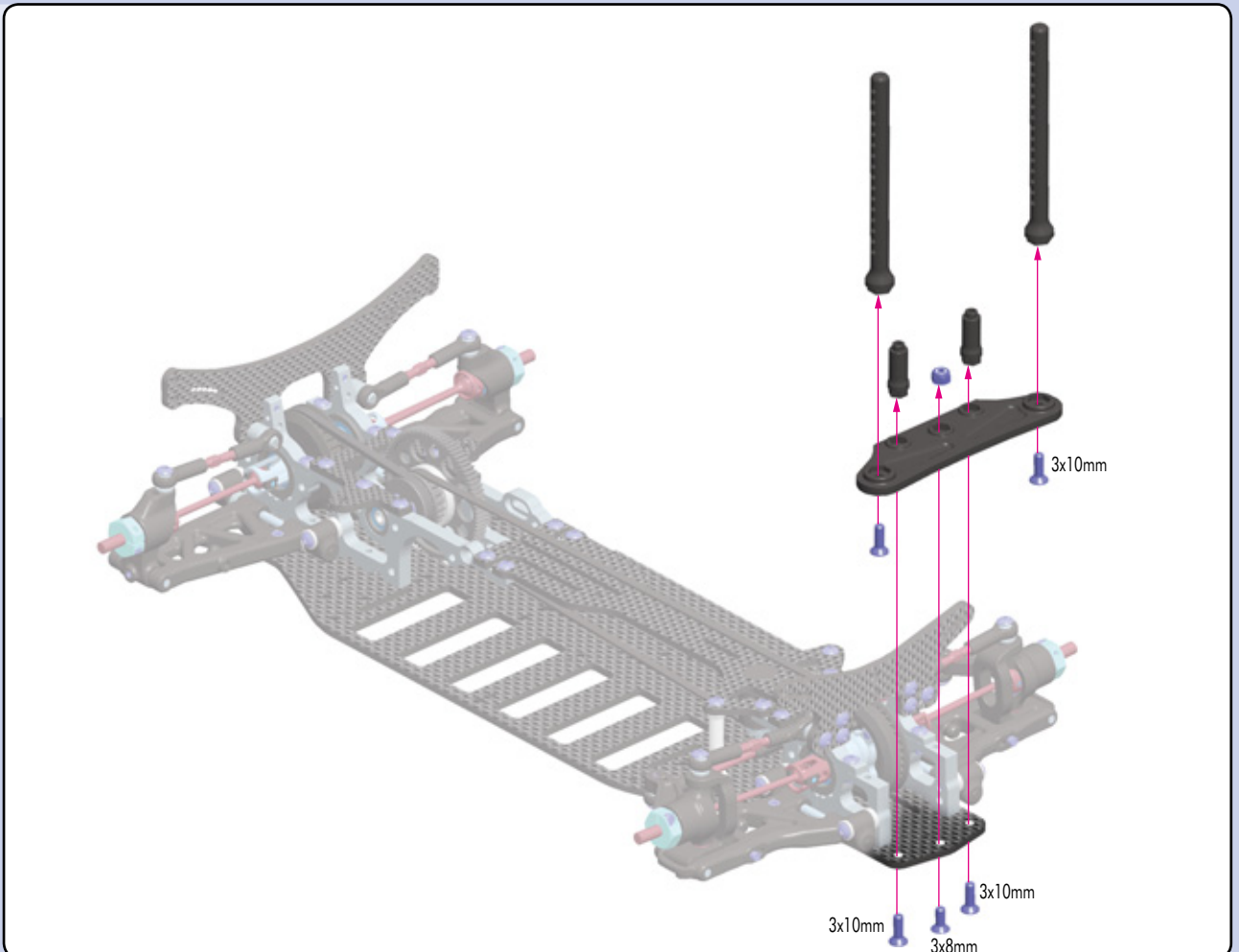

7. FRONT & REAR ASSEMBLY



903308
SFH M3x8

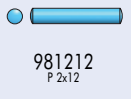
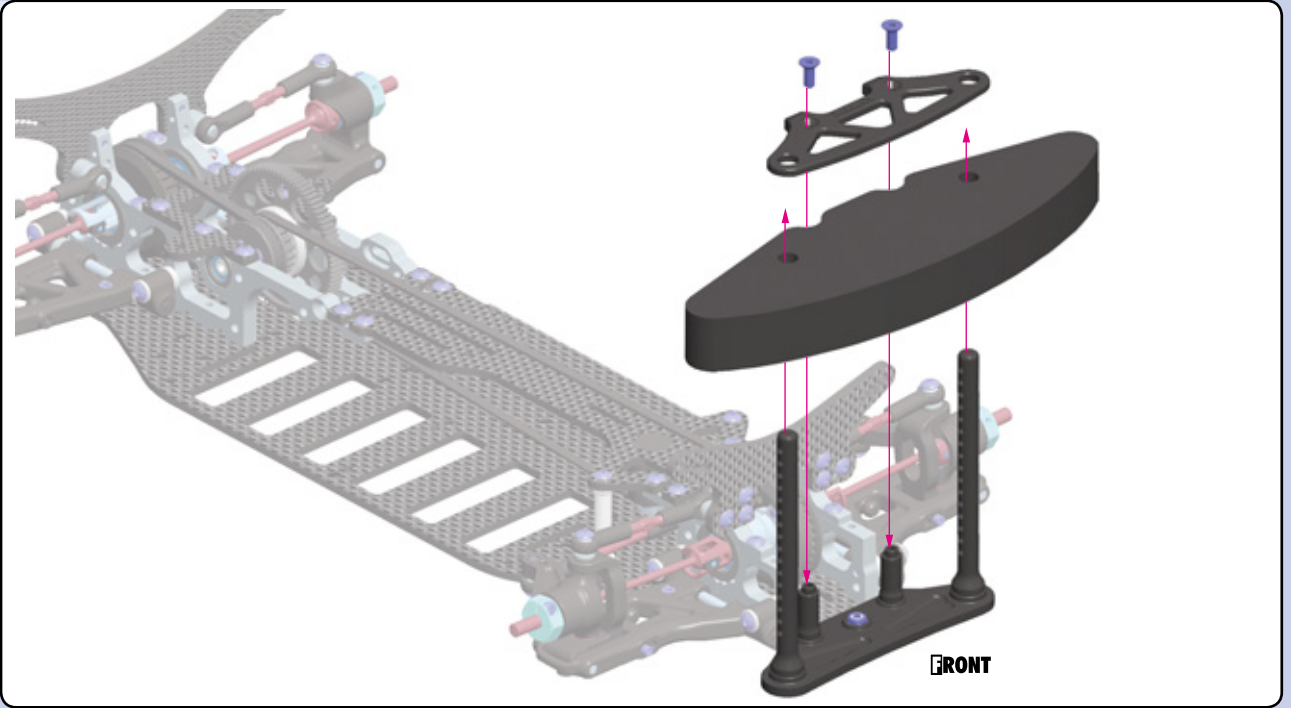

981212
P 2x12

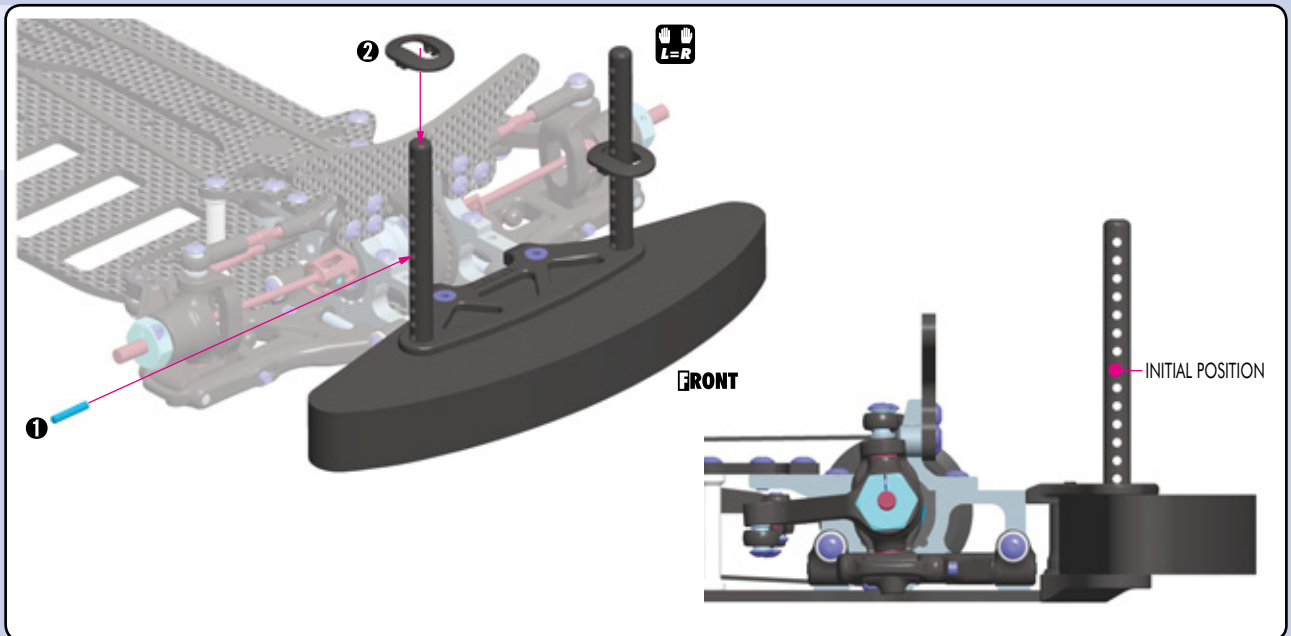

902308
SH M3x8

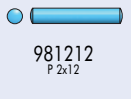

981212
P 2x12

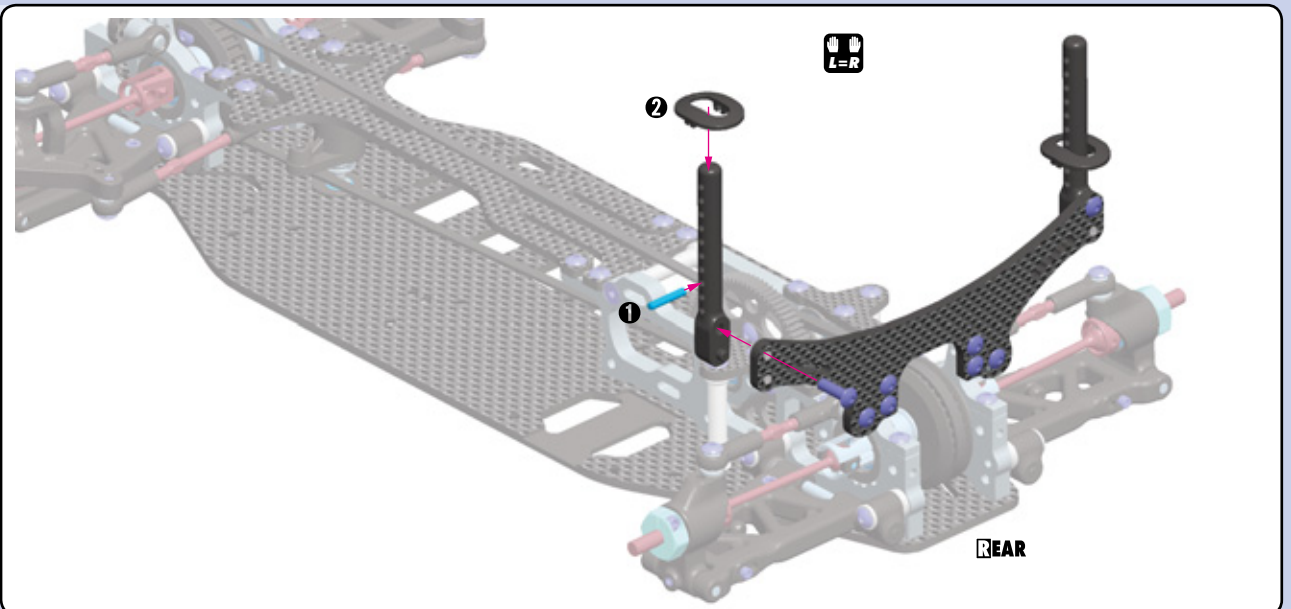

7. FRONT & REAR ASSEMBLY

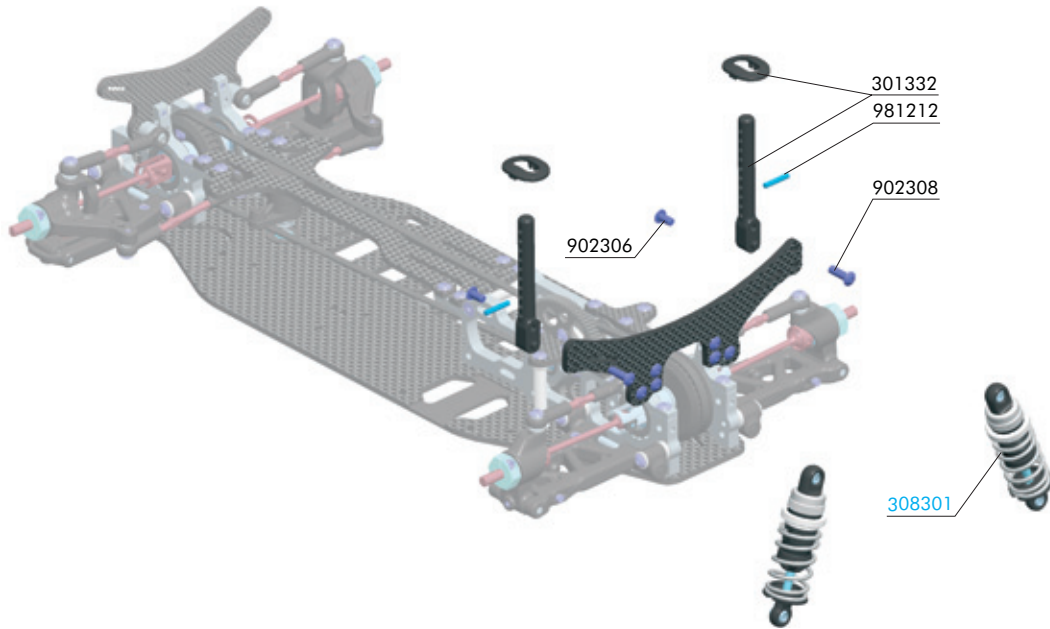

BAG

07

30 1332 T2 REAR BODY MOUNT SET 6MM
 90 2306 HEX SCREW SH M3x6 (10)
 90 2308 HEX SCREW SH M3x8 (10)

98 1212 PIN 2x12 (10)
 30 8301 T2 XRAY SHOCK ABSORBER-SET 4-STEP - SHORT (2)



902306
 SH M3x6

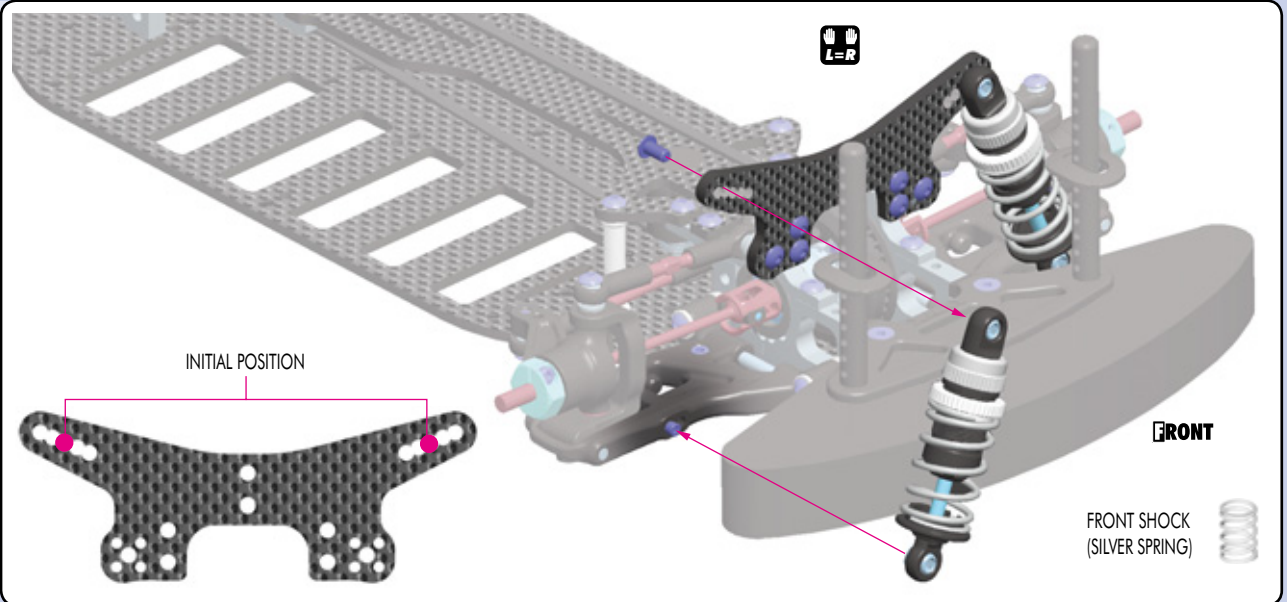

902306
 SH M3x6

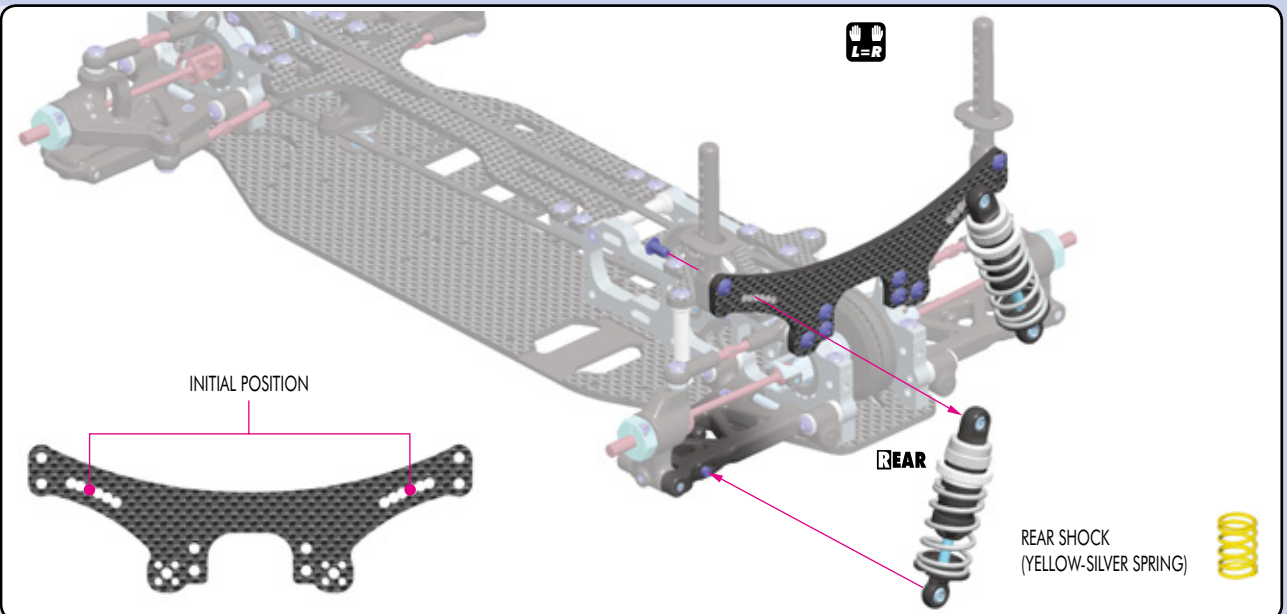

8. FINAL ASSEMBLY

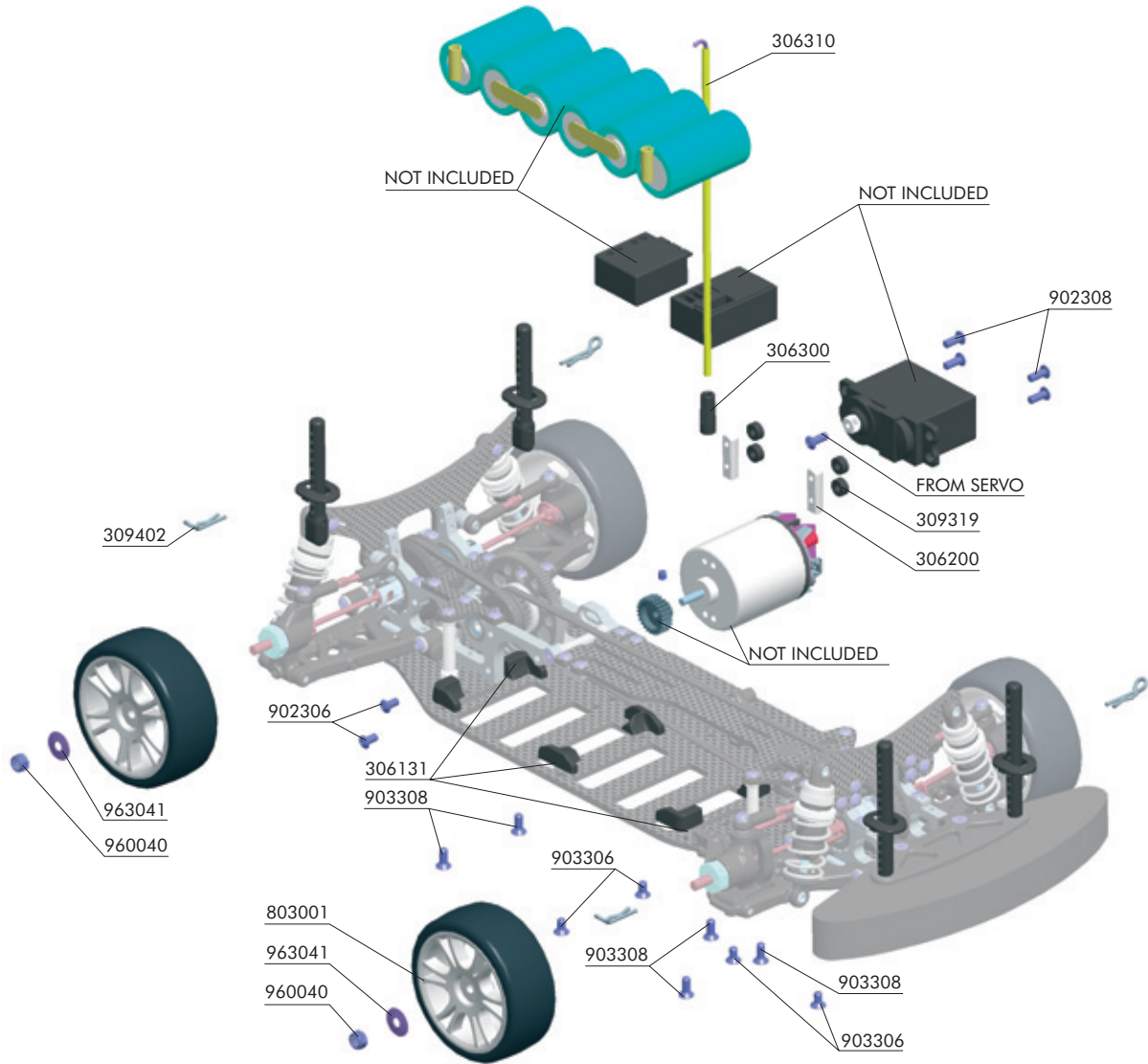

BAG

08

- 305716-34 PINION GEAR ALU HARD COATED - SHORT (OPTION)
- 30 6131 SET OF BATTERY BACKSTOPS
- 30 6163 T2 6-CELL GRAPHITE BATTERY STRAP (SET) - (OPTION)
- 30 6200 ALU SERVO MOUNT (2)
- 30 6300 ANTENNA MOUNT
- 30 6310 ANTENNA TUBE (2)
- 30 9319 UNIVERSAL SET OF PLASTIC SHIMS
- 30 9402 BODY CLIP FOR 6MM BODY POST (4)

- 80 3001 HUDY 24 MM WHEELS STARBURST - WHITE (4)
- 90 2306 HEX SCREW SH M3x6 (10)
- 90 2308 HEX SCREW SH M3x8 (10)
- 90 3306 HEX SCREW SFH M3x6 (10)
- 90 3308 HEX SCREW SFH M3x8 (10)
- 96 0040 NUT M4 (10)
- 96 3041 CONE WASHER ST 4x12 (10)



902308
SH M3x8



903306
SFH M3x6

If the servo does not fit properly, you may have to add shims between the servo tabs and the mounting posts. Shims are included in the Last Aid bag.

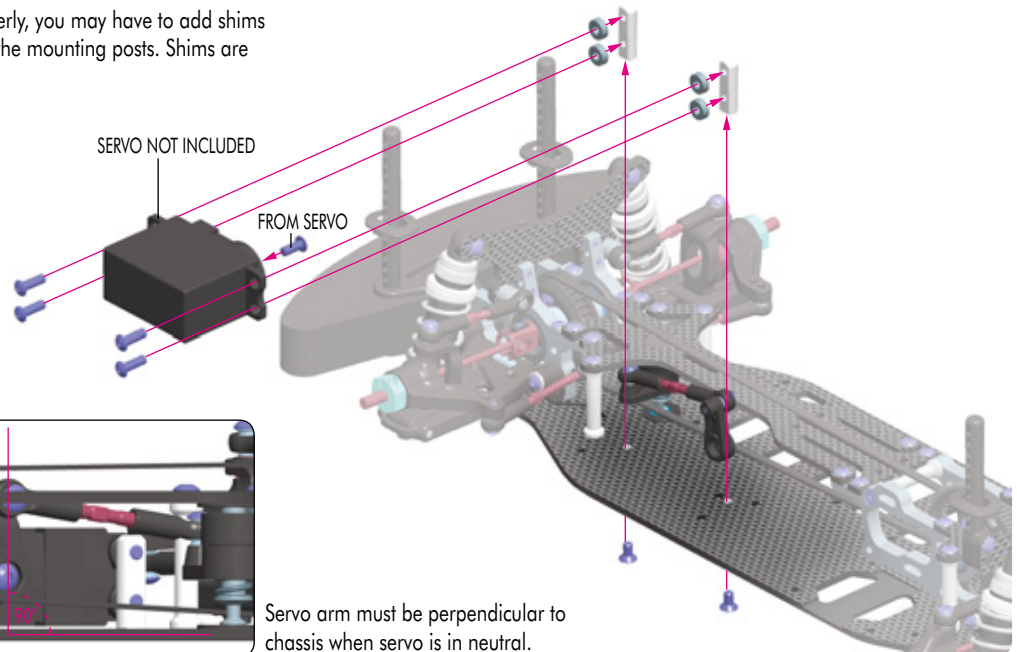

8. FINAL ASSEMBLY

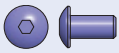

902306
SFH M3x6

Adjust the motor so the pinion meshes with the spur gear properly. Make sure the gear mesh is not too tight.

There should be a small amount of play between the teeth of the pinion gear and spur gear.

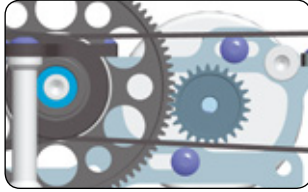

DETAIL

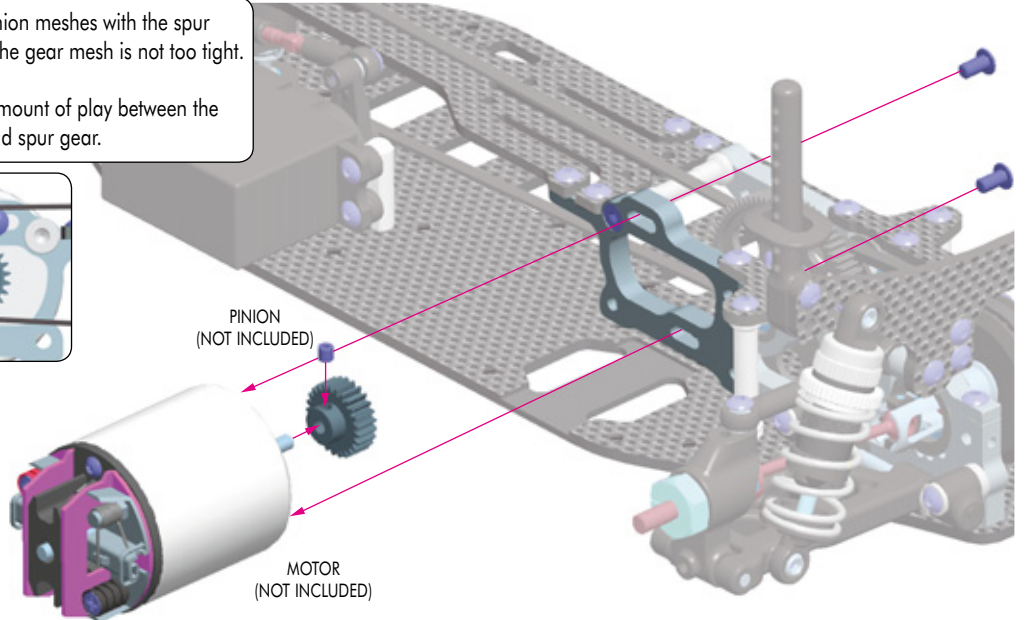

903308
SFH M3x8

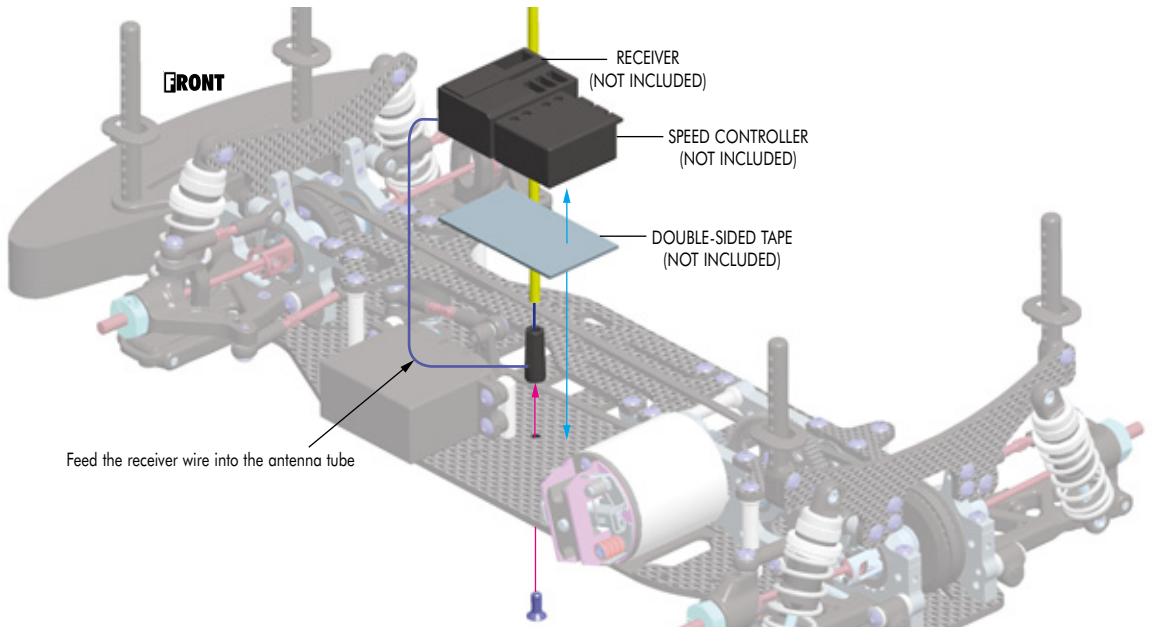

903306
SFH M3x6



903308
SFH M3x8

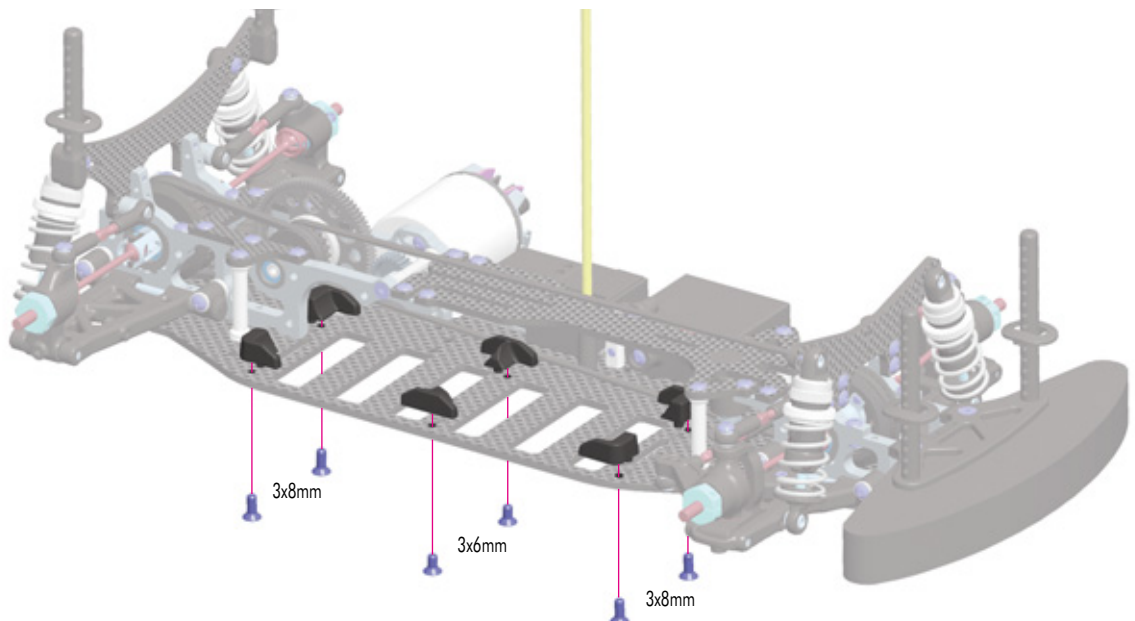

8. FINAL ASSEMBLY

4x



TIRES & INSERTS
(NOT INCLUDED)

WARNING!

Follow the adhesive manufacturer's instructions for proper use and safety. Wear proper eye and hand protection.



960040
N M4



963041
ST 4x12

DETAIL

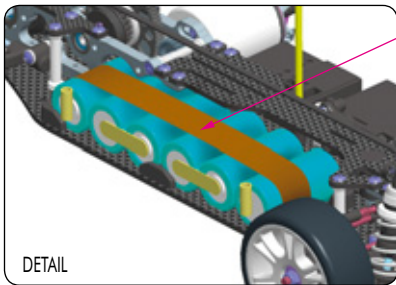
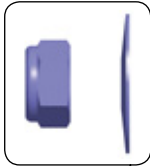

DETAIL

6-CELL INLINE BATTERY PACK
(NOT INCLUDED)

FIBRE TAPE
(NOT INCLUDED)

Make sure the wheel nuts are very tight, so the wheels do not loosen during racing.

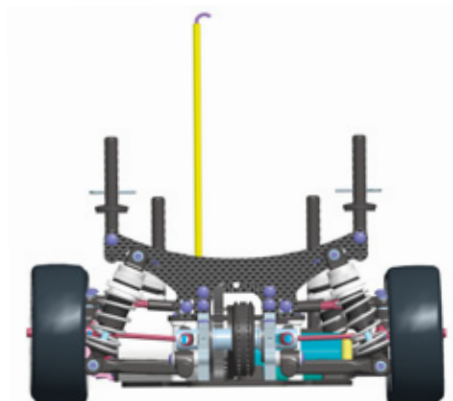
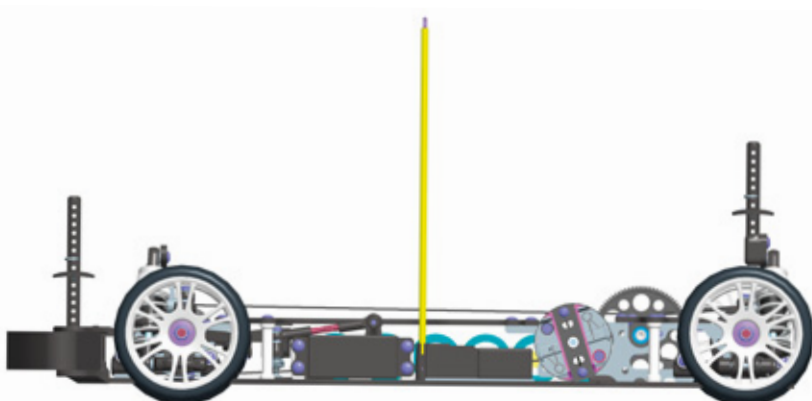



www.teamxray.com

XRAY MODEL RACING CARS

P.O. BOX 103
911 50 TREŇCÍN
SLOVAKIA, EUROPE
PHONE: ++421 905 402724
support@teamxray.com



8 581703 910077